

Q-Pumps

THE BEST PUMPING SOLUTIONS
FOR YOUR SANITARY APPLICATIONS



QP SERIES



QTS SERIES



QL SERIES

www.q-pumps.com

PLUG AND PLAY SOLUTIONS

Portable
&
Easy to
use
For Viscous
Products



QTS CART*



QDB SERIES*

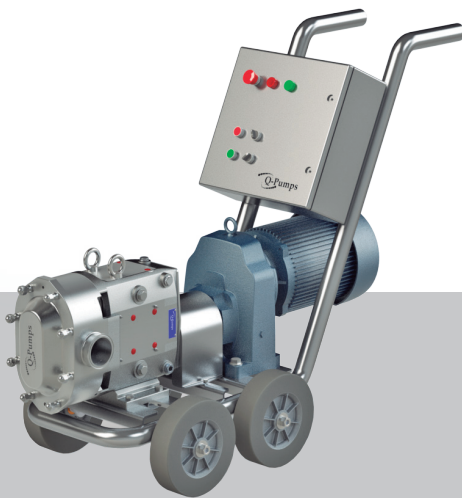

QP CART*

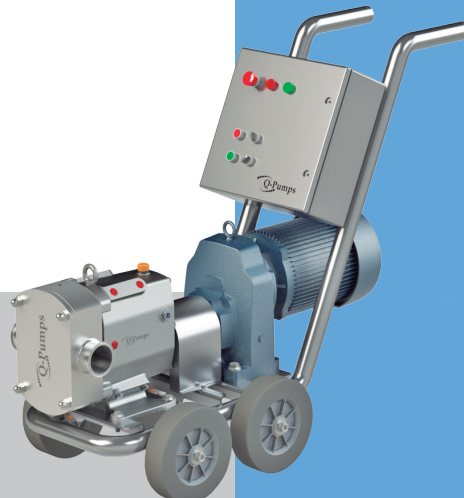

QL CART*

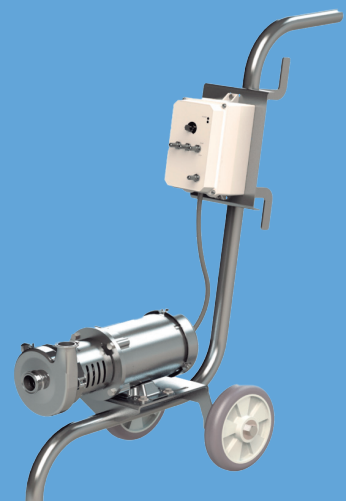

QC CART*

*Images for demonstration purposes only.
The product may vary, ask your distributor for details.

ABOUT US

Since 1997, Q-Pumps has been dedicated to the development and manufacturing of sanitary pumping equipment in order to provide the best solutions for the food, beverage, cosmetic and pharmaceutical industries. We serve applications in 58 countries, with the perfect combination of technology and a highly skilled team of experts, with whom we are able to exceed the expectations of our costumers requirements around the world.

MATERIALS

All our products are built in Stainless Steel Series 300. The parts that have contact with the pumped product are 316L and the rest 304. In this way, we guarantee the quality and durability of our products.

SPECIAL REQUESTS

We manufacture pumps under any customer specification. From a special type of connection, different surface finishes, different materials such as titanium, Hastelloy C-276, etc... Currently we offer in all our pump lines different port types like Sanitary Clamp, Bevel Seat, NPT, Flanged, SMS, DIN, as standard configuration. The standard surface finish of the pumps is a maximum of 32 μm Ra. Additionally they can be sandblasted or electropolished upon request.

SPARE PARTS

Some of our product lines offer spare parts compatible with many of the major brands on the market.

GROWTH

Since 2020 Q-Pumps has an office in Houston, Texas, and from this location we serve the North American Market. In Mexico, we have installed a new electropolishing facilities, we are very excited to continue serving our costumers with the quality, service and lasting performance of our products.



QTS



QP



QL



QIS



QC



MIXERS

	Q	μ	P	T
	FLOW	VISCOSITY	PRESSURE	TEMPERATURE
QTS	850 gpm / 3218 lpm	up to 1 000 000 cP	362 psi / 25 bar 836 ft / 255 m	150 °C / 302 °F
QP	450 gpm/ 1700 lpm	up to 1 000 000 cP	500 psi / 34.5 bar 1155 ft / 352 m	150 °C / 302 °F
QL	210 gpm/ 795 lpm	up to 1 000 000 cP	290 psi / 20 bar 670 ft / 204 m	150 °C / 302 °F
QIS	800 gpm / 3028 lpm	up to 800 cP	145 psi / 10 bar 334 ft / 102 m	200 °C / 392 °F
QWP	700 gpm / 2650 lpm	up to 500 cP	125 psi / 8.6 bar 288 ft / 87 m	120 °C / 248 °F
QC	1200 gpm / 4542 lpm	up to 600 cP	135 psi / 9.3 bar 311 ft / 95 m	120 °C / 248 °F
QCB+	700 gpm / 2650 lpm	up to 600 cP	135 psi / 9.3 bar 311 ft / 95 m	120 °C / 248 °F
QIM/ QDB	420 gpm / 1590 lpm	up to 600 cP	85 psi / 5.85 bar 196 ft / 60 m	120 °C / 248 °F
QVM	90 gpm / 340 lpm	up to 100 000 cP	145 psi / 10 bar 334 ft / 102 m	120 °C / 248 °F
QDU	60 gpm / 227 lpm	up to 1 000 000 cP	300 psi / 20.7 bar 693 ft / 211 m	120 °C / 248 °F

REFERENCE DATA

Technical data shown here is for commercial reference.
This information may change according to the application.



Q 850 gpm /
3218 lpm

μ up to 1 000 000 cP

P 362 psi / 25 bar
836 ft / 255 m

T 150 °C
302 °F

CHARACTERISTICS

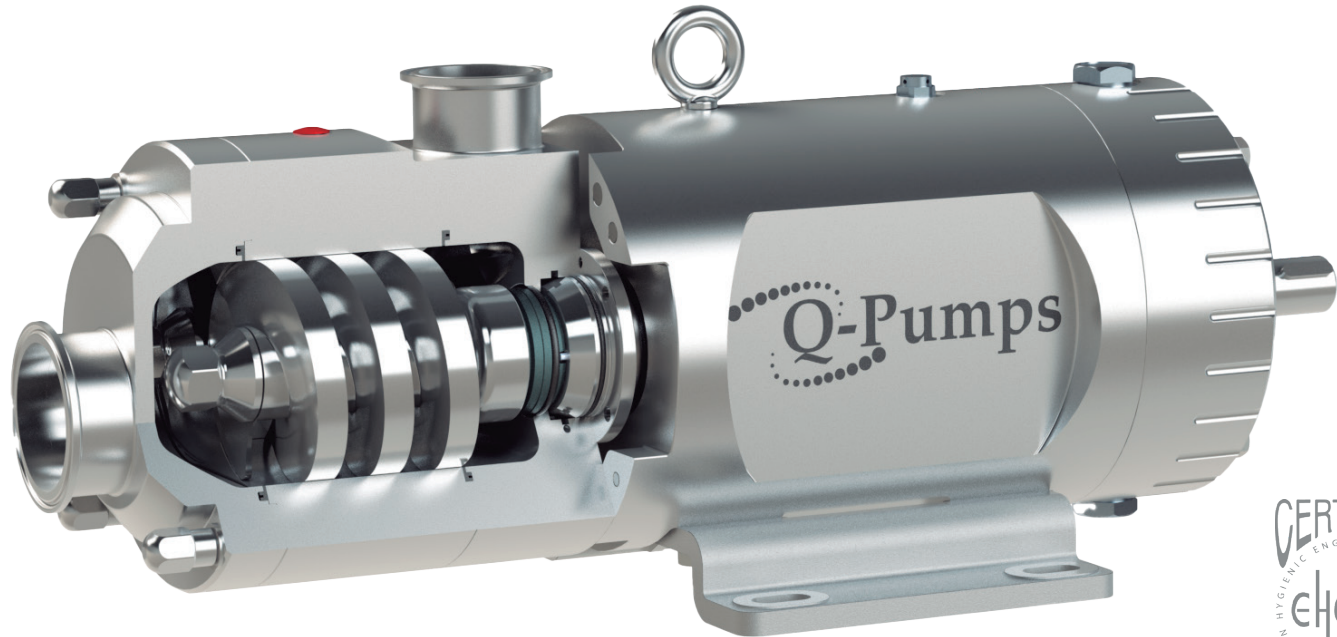

- Gentle product pumping
- Superior handling of suspended solids
- Constant flow, free of pulsations
- Process and CIP with the same equipment
- Bidirectional
- Ideal for abrasive products
- Built in 100% Stainless Steel
- Speeds up to 3500 rpm
- No dead-zones and 100% drainable
- Wet parts in SS 316L
- Easy assembly
- 32 μin (0.8 μm) Ra maximum surface finish

APPLICATIONS





DIFFERENT SIZES

QTS-100

Front and Top ports:
1.5", 2"
40, 50 mm

NEW!



NEW!

QTS-400

Front and Top ports:
4", 6"
100, 150 mm

QTS-350

Front port: 4", 6" 100, 150 mm	Top Port: 3", 4" 80, 100 mm
--------------------------------------	-----------------------------------

Dosing Pump QTS-025

Front and Top ports:
1/2", 3/4", 1"
15, 20, 25 mm

* Ideal for dosing or low flow applications

QTS-200

Front port: 2", 2.5", 3" 50, 65, 80 mm	Top Port: 2", 2.5" 50, 65 mm
--	------------------------------------

RECTANGULAR INLET

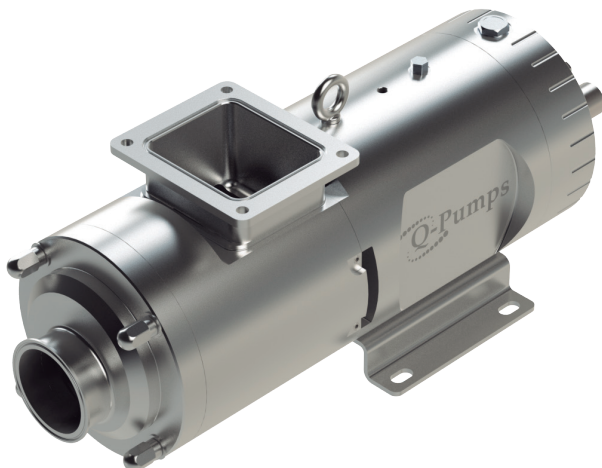

- Ideal for pasty products with high viscosities (100 000 to 1 000 000 cP)
- Ideal for products with high air or gas content
- Ideal for applications with low NPSH
- CIP capable
- Available in QTS-200 and QTS-300 sizes

PERFORMANCE

	Maximum Capacity				Port Sizes		Maximum Differential pressure	Viscosity	Temperature
	gpm		lpm		in	DN mm			
	Process Flow	CIP Flow	Process Flow	CIP Flow					
QTS 025	8	16	30	60	1/2", 3/4", 1"	15, 20, 25	150 psi/10bar	1 000 000 cP 248 °F (120°C)	
QTS 100	35	70	132	265	1.5"/2"	40, 50	260 psi/18bar		
QTS 200	93	185	352	700	2", 2.5", 3"	50, 65, 80	360 psi/25 bar		
QTS 300	223	405	844	1533	3", 4"	80, 100			
QTS 350	399	642	1510	2430	3", 4", 6"	80, 100, 150			
QTS 400	570	850	2158	3218	4", 6"	100, 150			

AVAILABLE SEALS

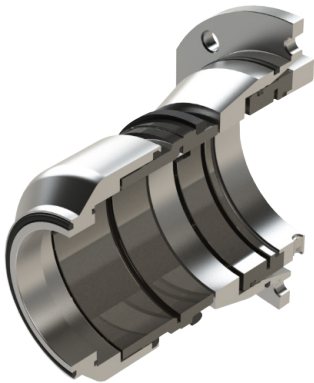

Mechanical
(Single & Double)



O-Ring
(Single & Double)



Lip Seal

With different screw options for soft solids handling, different pressures and flow requirements





Q 450 gpm /
1700 lpm

μ up to 1 000 000 cP

P 500 psi / 34.5 bar
1155 ft / 352 m

T 150 °C
302 °F

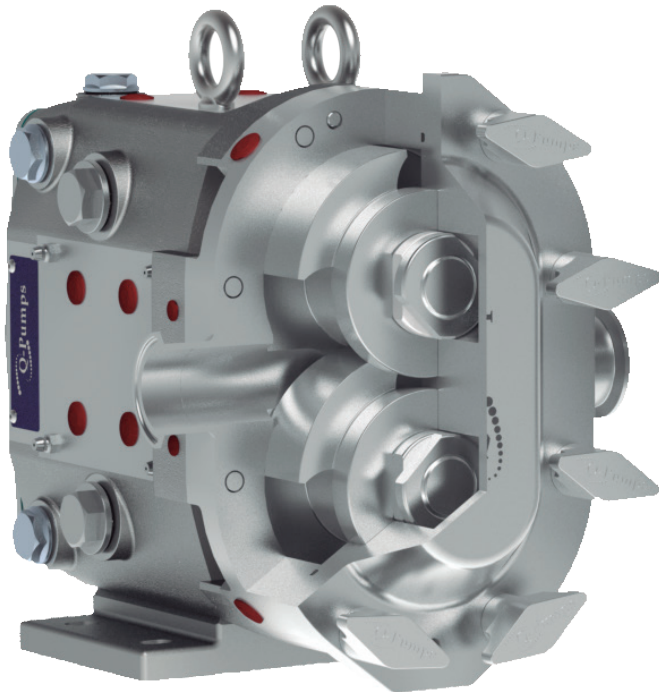

QP1 SERIES



QP2 SERIES

CHARACTERISTICS

- Ideal for high pressures with low and high viscosity products
- Interchangeable with other circumferential piston pumps
- Stronger shafts made on 17-4 PH
- Stainless steel gear box
- Helical gears for extended service life and lower noise
- Different options of mechanical seals, single or double
- Gear box designed to be mounted in four positions
- Alloy 88 Rotors for tight clearances
- Cover and body made of 316L stainless steel
- 32 μin (0.8 μm) Ra maximum surface finish

APPLICATIONS





CROSS REFERENCE

Q-Pumps	Other Brands
QP1	Universal 1/ZP1 / TRA 10
QP2	Universal 2 /ZP2 / TRA 20

To see the compatibility and equivalences with other brands, visit our website in the Cross Reference section:
http://www.q-pumps.com/cross_reference.php

PUMP PERFORMANCE

QP1 SERIES

Model QP1	Nominal Capacity		Displacement		Maximum Differential Pressure		Standard Port Size		Optional Port Size		Maximum Speed rpm	Temperature Range	
	gpm	lpm	Gal/Rev	L/Rev	psi	bar	in	DN mm	in	DN mm		°F	°C
6	7	24.8	0.0082	0.031	200	13.8	1"	25	1 1/2"	40	800	-40° a 300°	-40° a 149°
15	10	37.6	0.0142	0.054	200	13.8	1 1/2"	40	-	-	700		
18	17	65.9	0.029	0.110	200	13.8	1 1/2"	40	2"	50	600		
30	36	136.6	0.060	0.227	200	13.8	1 1/2"	40	2"	50	600		
40	46	172.6	0.076	0.228	150	10.3	2"	50	2 1/2"	65	600		
60	92	347.5	0.153	0.579	200	13.8	2 1/2"	65	3"	80	600		
130	152	576.8	0.254	0.961	200	13.8	3"	80	-	-	600		
220	313	1185.5	0.522	1.976	200	13.8	4"	100	-	-	600		
320	452	1712.3	0.754	2.854	200	13.8	6"	150	-	-	600		

Rectangular Inlet Option													
	Nominal Capacity		Displacement		Maximum Differential Pressure		Rectangular Inlet (WxL)		Discharge Port Size		Maximum Speed rpm	Temperature Range	
	gpm	lpm	Gal/Rev	L/Rev	psi	bar	in	mm	in	DN mm		°F	°C
34	24	90.8	0.060	0.227	200	13.8	1.75 x 6.75	44 x 171	2"	50	400	-40° a 300°	-40° a 149°
64	61	231.6	0.153	0.579	200	13.8	2.24 x 8.82	57 x 224	2 1/2" (3")	65 (80)	400		
134	102	384.6	0.254	0.961	200	13.8	2.97 x 9.25	75 x 235	3"	80	400		
224	208	788.8	0.521	1.972	200	13.8	3.78 x 11	98 x 279	4"	100	400		

QP2 SERIES

Model QP2	Nominal Capacity		Displacement		Maximum Differential Pressure		Standard Port Size		Optional Port Size		Maximum Speed rpm	Temperature Range	
	gpm	lpm	Gal/Rev	L/Rev	psi	bar	in	DN mm	in	DN mm		°F	°C
6	8	1.0	0.0082	0.031	300	20.7	1"	25	1 1/2"	40	1000	-40° a 300°	-40° a 149°
15	11	43.0	0.0142	0.054	250	17.2	1 1/2"	40	-	-	800		
18	20	76.8	0.029	0.110	200	13.8	1 1/2"	40	2"	50	700		
30	36	136.3	0.060	0.227	250	17.2	1 1/2"	40	2"	50	600		
40	46	172.6	0.076	0.288	150	10.3	2"	50	2 1/2"	65	600		
45	59	222.6	0.098	0.371	450	31.0	2"	50	-	-	600		
60	92	347.5	0.153	0.579	300	20.7	2 1/2"	65	3"	80	600		
130	152	576.8	0.254	0.961	200	13.8	3"	80	-	-	600		
180	228	863.0	0.380	1.438	450	31.0	3"	80	-	-	600		
210	301	1140.0	0.502	1.900	500	34.5	4"	100	-	-	600		
220	313	1185.5	0.522	1.976	300	20.7	4"	100	-	-	600		
320	452	1712.3	0.754	2.854	300	20.7	6"	150	-	-	600		

Rectangular Inlet Option													
	Nominal Capacity		Displacement		Maximum Differential Pressure		Rectangular Inlet (WxL)		Discharge Port Size		Maximum Speed rpm	Temperature Range	
	gpm	lpm	Gal/Rev	L/Rev	psi	bar	in	mm	in	DN mm		°F	°C
34	24.0	90.8	0.060	0.227	250	17.2	1.81 x 6.84	44 x 174	2"	50	400	-40° a 300°	-40° a 149°
64	61.2	231.6	0.153	0.579	300	20.7	2.44 x 9.0	62 x 229	2 1/2" (3")	65 (80)	400		
134	101.6	384.6	0.254	0.961	200	13.8	3.19 x 9.38	81 x 238	3"	80	400		
224	208	788.8	0.521	1.972	300	20.7	4.06 x 11.25	103 x 2786	4"	100	400		



Q 210 gpm /
795 lpm

μ up to 1 000 000 cP

P 290 psi / 20 bar
670 ft / 204 m

T 150 °C
302 °F

CHARACTERISTICS



Hexagonal or flat bolt options

- 3-A Certified and designed to comply with EHEDG standards
- Front access seal that provides quick cleaning and less downtime
- Standard Bi-Wing rotors for better performance
- Stainless steel gear box

- Multiple rotor options available
- Stainless steel 316L cover and body
- 32 μin (.8 μm) Ra maximum surface finish
- Different types of seals for each application
- Tri-Clamp connections as standard. Other connections available

APPLICATIONS



QL Series	Model	Displacement			Standard Connection Size		Maximum Differential Pressure		Maximum Speed
		Liters / per rev.	lpm	gpm	DN mm	in	bar	psi	rpm
QL - A	QL - A10	0.050	50.0	13.2	25	1.0	20	290	1000
	QL - A15	0.120	96.0	25.4	40	1.5	12.1	175	800
	QL - A20	0.210	168.0	44.4	50	2.0	7.9	115	800
QL - B	QL - B20	0.410	287.0	75.8	50	2.0	12.1	175	700
	QL - B25	0.620	434.0	114.7	65	2.5	7.9	115	700
QL - C	QL - C30	1.020	612.0	161.7	80	3.0	12.1	175	600
	QL - C40	1.440	864.0	228.3	100	4.0	7.9	115	600

ADVANTAGES

- Low cost with excellent performance
- Front access that allows quick cleaning
- Different rotor types to best suit a wide range of product types
- CIP capable



Bi-Wing Rotor:
Standard

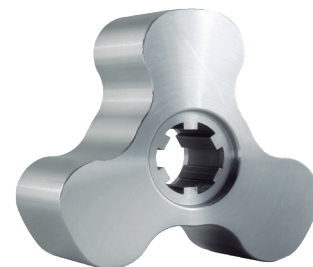

Tri-Lobe Rotor

COVER OPTIONS

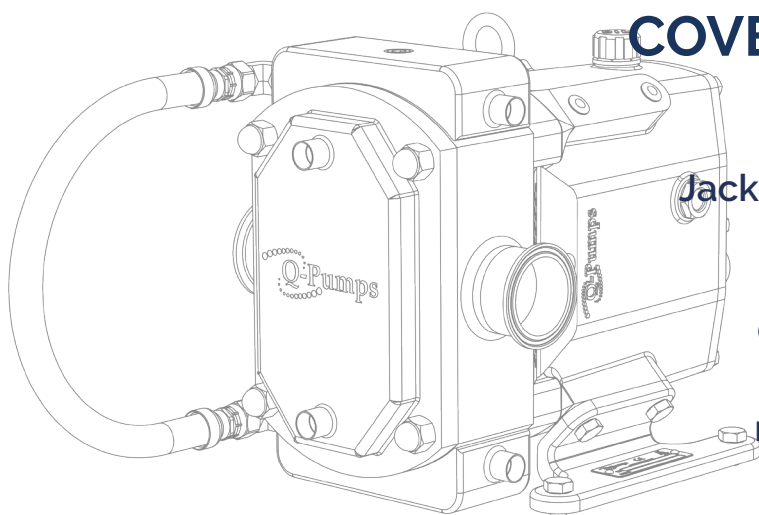

Jacketed cover and or housing

Cover with pressure relief valve

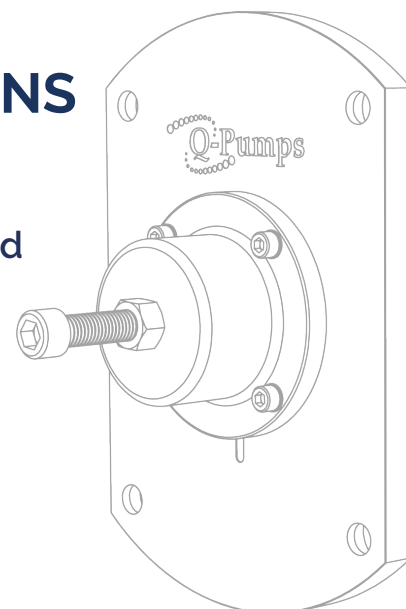



QIS SERIES

INTERNAL SEAL CENTRIFUGAL PUMP



800 gpm /
3028 lpm



up to 800 cP



145 psi / 10 bar
334 ft / 102 m



200 °C
392 °F

SANITARY CENTRIFUGAL PUMP WITH AN INTERNAL SEAL

Ideal for sanitary as well as non-sanitary applications, perfect for the food, beverage and pharmaceutical industries. *Designed for greater efficiency and hygiene.*

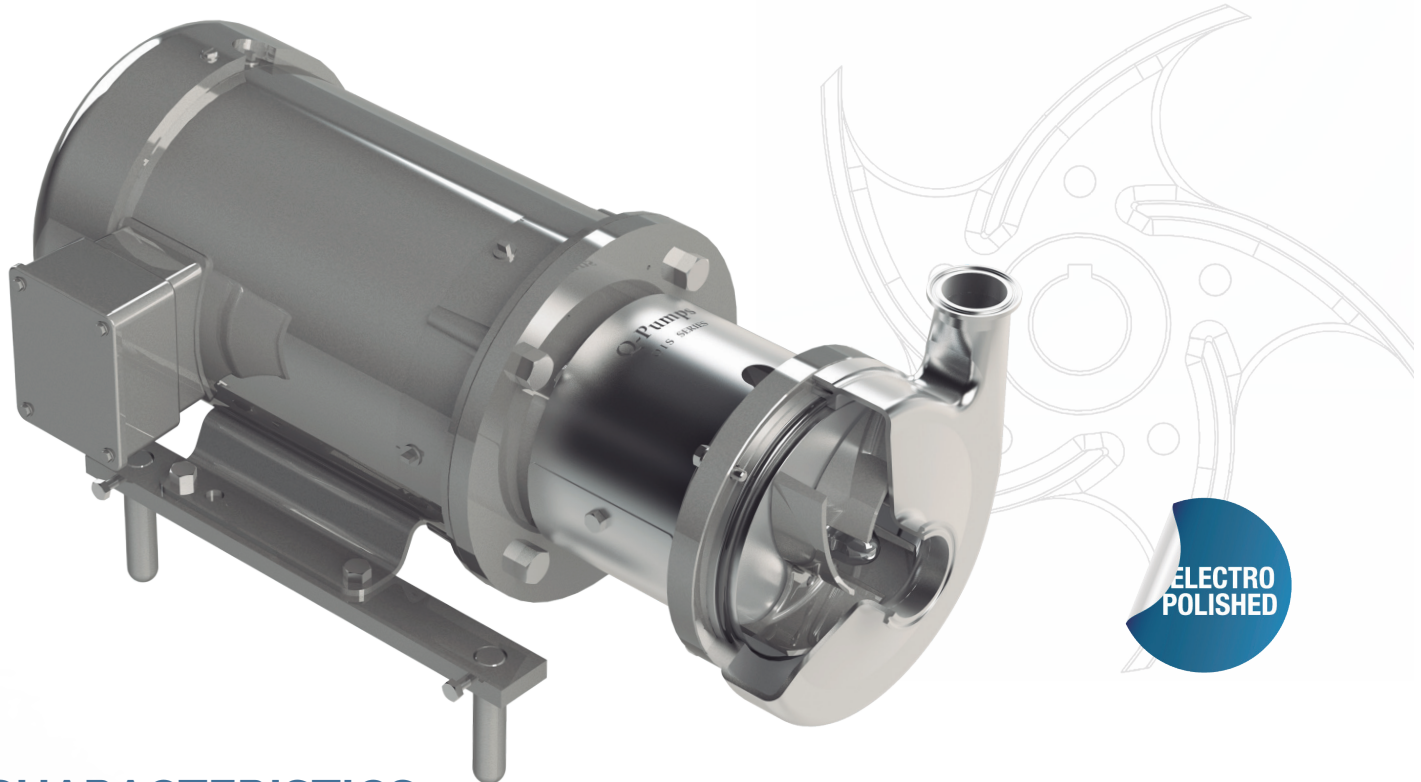

CHARACTERISTICS

- 3A certified and designed to comply with EHEDG standards.
- Double mechanical seal option available
- Improved hygienic design
- Wet parts in Stainless Steel 316L
- Electropolished surface finish in wet parts
- Different port options available
- Volute casing and semi open impeller for greater efficiency
- Fully drainable with discharge port at 90° or with drain port option

APPLICATIONS

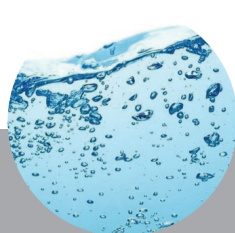

QWP SERIES

FREE FLOW CENTRIFUGAL PUMP

NEW!

Q 700 gpm /
2650 lpm

μ up to 500 cP

P 125 psi / 8.6 bar
288 ft / 87 m

T 120 °C
248 °F



ELECTRO
POLISHED

CHARACTERISTICS

- 100% electropolished
- New Free Flow impeller (straight vanes) that allows solid passage.
- Easy to switch between a QIS 328 to QWP 328
- Lower side discharge or drain option.
- Ideal for fluids and aqueous slurries.
- Volute Casing
- Designed under 3-A and EHEDG hygienic standards
- Available in QWP 328 and 428 size

ADVANTAGES OF HAVING A FREE FLOW IMPELLER

- It doesn't get stuck with the branches, leaves of the grapes.
- Doesn't damage the final product

APPLICATIONS





QC / QC+ SERIES

EASY ASSEMBLY AND HIGH-FLOW CENTRIFUGAL PUMP



Q 1200 gpm /
4542 lpm

μ up to 600 cP

P 135 psi / 9.3 bar
311 ft / 95 m

T 120 °C
248 °F

CHARACTERISTICS



- Wet parts in Stainless Steel 316L
- NEMA and IEC standards available
- Open impeller
- Connections: Clamp (standard), Flange, NPT, Weldable, Bevel Seat, DIN, SMS
- 32 μin (.8 μm) Ra maximum surface finish
- Volute casing with suction in the center
- Brackets and legs in stainless steel

QC+ SERIES

- Easy assembly and better hygienic design.
- The stub shaft gives better support when mounted with the collar (vs other brands)
- Rotor fastened with key and sanitary cap nut
- Any C Series can be converted to a QC + with a "Kit +"



APPLICATIONS

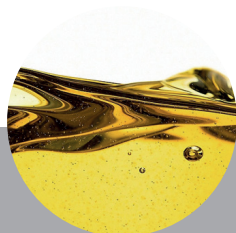

THE LEGACY PUMP QC SERIES

AVAILABLE AS
QC OR QC+
designs



STANDARD MECHANICAL SEAL

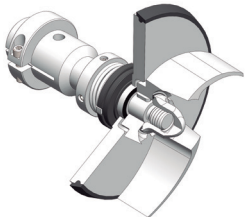

“D” SEAL

Designed for long life service. The typical applications for this seal are: dairy products, tomatoe sauce, beverages, also applicable for acid cleaning solutions and detergents. It is not recommended for applications when the fluid is abrasive or corrosive; or when the fluid dries and forms layers.

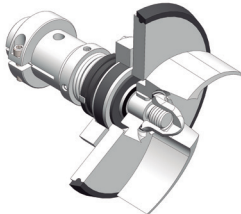

“DG” SEAL

The clamped-in sea/ type “DG” utilizes the seal type “D” rotating components, plus choice of silicon carbide, ceramic or tungsten carbide stationary seal seat. It is used for maximum corrosion resistance, in pure water applications, with abrasive or non-lubricated products. It is ideal for liquid sugar applications, acids and caustic soda.

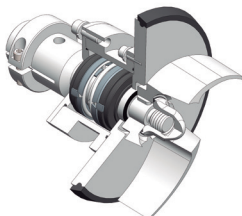

“E” SEAL

Water cooled balanced double seal. It consists of two rotating seals placed inside a stuffing box, which is usually flooded to cool and lubricate the seal. This seal can be pressurized with fluid directly from the discharge of the pump and is used in slurries, tacky products or when there are high temperatures up to 212 °F and vacuum up to 28” Hg applications.



QCB+ SERIES

INTERNAL SEAL CENTRIFUGAL PUMP

NEW!



Q 700 gpm
2650 lpm

μ up to 600 cP

P 135 psi / 9.3 bar
311 ft / 95 m

T 120 °C
248 °F

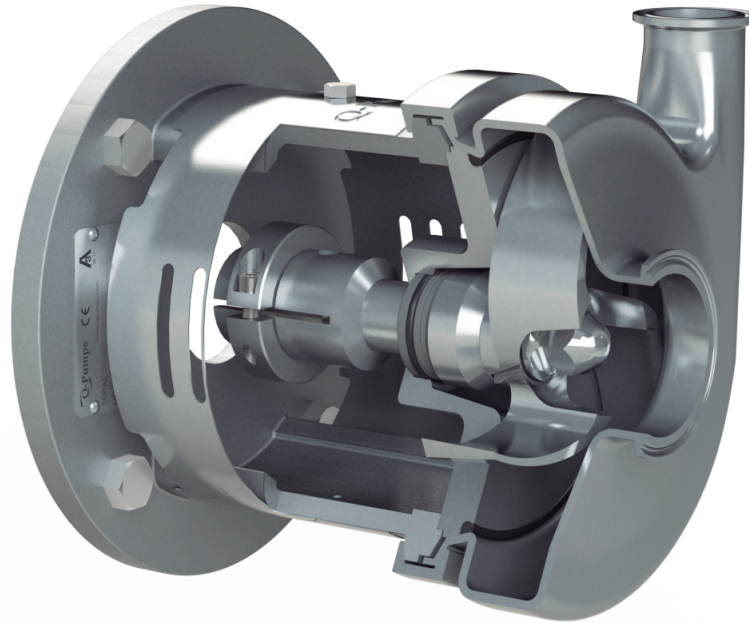

Based on the QC+ Series featuring an internal balanced sanitary mechanical seal designed to keep seal faces cool and minimize product buildup.

CHARACTERISTICS

- Dimensionally and hydraulically interchangeable with the QC, QC+ and any competitor C Series pump
- Designed for hot wort pumping
- Internal design that keeps the mechanical seal improving lubrication.
- Ideal for handling hot products at boiling point



QCB+ CART

- Versatile- easy to move
- Ideal for the brewing industry

APPLICATIONS





MIXERS SERIES - QIM

IN-LINE MIXERS



Q 420 gpm
1590 lpm

μ up to 600 cP

P 85 psi / 5.85 bar
196 ft / 60 m

T 120 °C
248 °F

**THE MOST
EFFICIENT
AND
VERSATILE
IN-LINE
MIXER IN THE
MARKET**

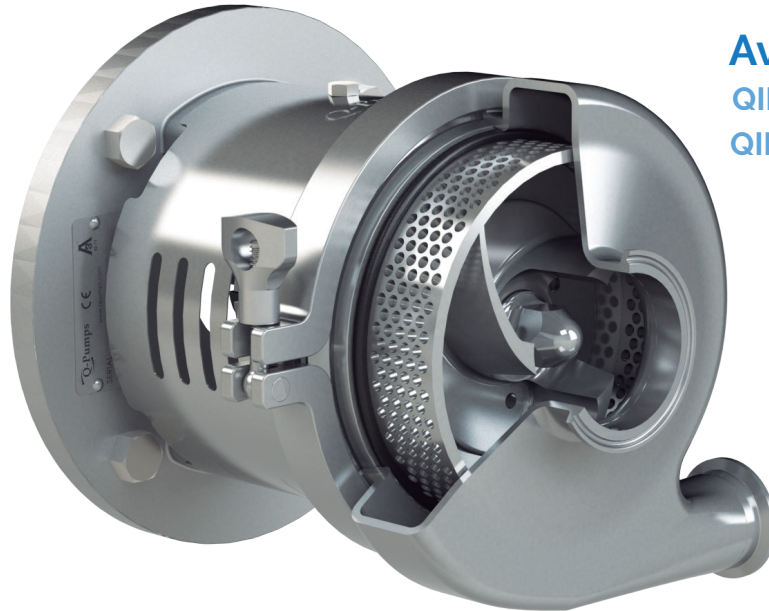

Available Sizes:

QIM+214 QIM+316
QIM+318 QIM+428

CHARACTERISTICS

- Semi-open impeller design to keep pressurized and achieve better lubrication in the mechanical seal.
- Completely drainable with the discharge in horizontal position
- Interchangeable backplates for each application
- Easy installation, operation and maintenance
- Built in SS 316L with surface finish on all surfaces in contact with the fluid 32 Ra maximum
- Use of o-ring to achieve a better seal

AVAILABLE BACKPLATES



Straight radial slots

For powder mixing and lump disintegration

Type 1 (1/8") Type 3 (1/4")
Type 2 (3/16")



Small radial holes

For emulsification

Type 10 (1/8") Type 12 (1/4")
Type 11 (3/16")



Big radial holes

For chopping soft solids into smaller particles

Type 13 (3/8") Type 15 (7/8")
Type 14 (5/8")

APPLICATIONS





MIXERS SERIES - QDB

DRY BLENDERS



Q 420 gpm /
1590 lpm

μ up to 600 cP

P 85 psi / 5.85 bar
196 ft / 60 m

T 120 °C
248 °F



POWDER SUCTION RATE*

Model	kg/hr	lb/hr
214	2 580	5 688
316	3 300	7 275
318	4 860	10 714
428	18 000	39 683

* Subject to powder properties

CHARACTERISTICS

The Q-Pumps **Dry Blender QDB**, consists in an **In-line Mixer QIM** coupled to a table with a hopper and integrated valve for operator's convenience.

- Stainless Steel Hopper
- Front loading seal to facilitate maintenance
- Stainless steel table
- Wheels with brakes

APPLICATIONS

- Homogenization
- Powder mixing
- Emulsification
- Adding flavors
- Disintegration of solids
- Dissolution





MIXERS SERIES - QVM

HIGH VISCOSITY MIXERS



Q 90 gpm /
340 lpm

μ up to 100 000 cP*

P 145 psi / 10 bar
334 ft / 102 m

T 120 °C
248 °F

* Subject to fluid properties



QTS Twin
Screw Pump

The QTS pump creates the required suction for powders and liquids, making the mixing process inside the QIM pump faster and easier.

THE PERFECT MIXER FOR HIGH VISCOSITY PRODUCTS

APPLICATIONS





QDU SERIES

DRUM UNLOADING SYSTEM



60 gpm /
227 lpm



up to 1 000 000 cP



300 psi / 20.7 bar
693 ft / 211 m



120 °C
248 °F

QDU is the world's most advanced Drum Unloading System, delivering the fastest transfer rates, maximum product recovery, simple cleaning and ease of use.

CHARACTERISTICS

- Energy efficient electric motor drive
- Unload rate up to 60 gpm (depending on the viscosity)
- 3-A and EHEDG certified QTS Twin Screw Pump
- Electric drum Unloader with QTS pump provides a substantial increase in efficiency over air-operated pumps
- Easy to use touch screen control
- Quieter operation from 60 dB to 75 dB
- Variable speed drive enables full speed control for both product and CIP duties.

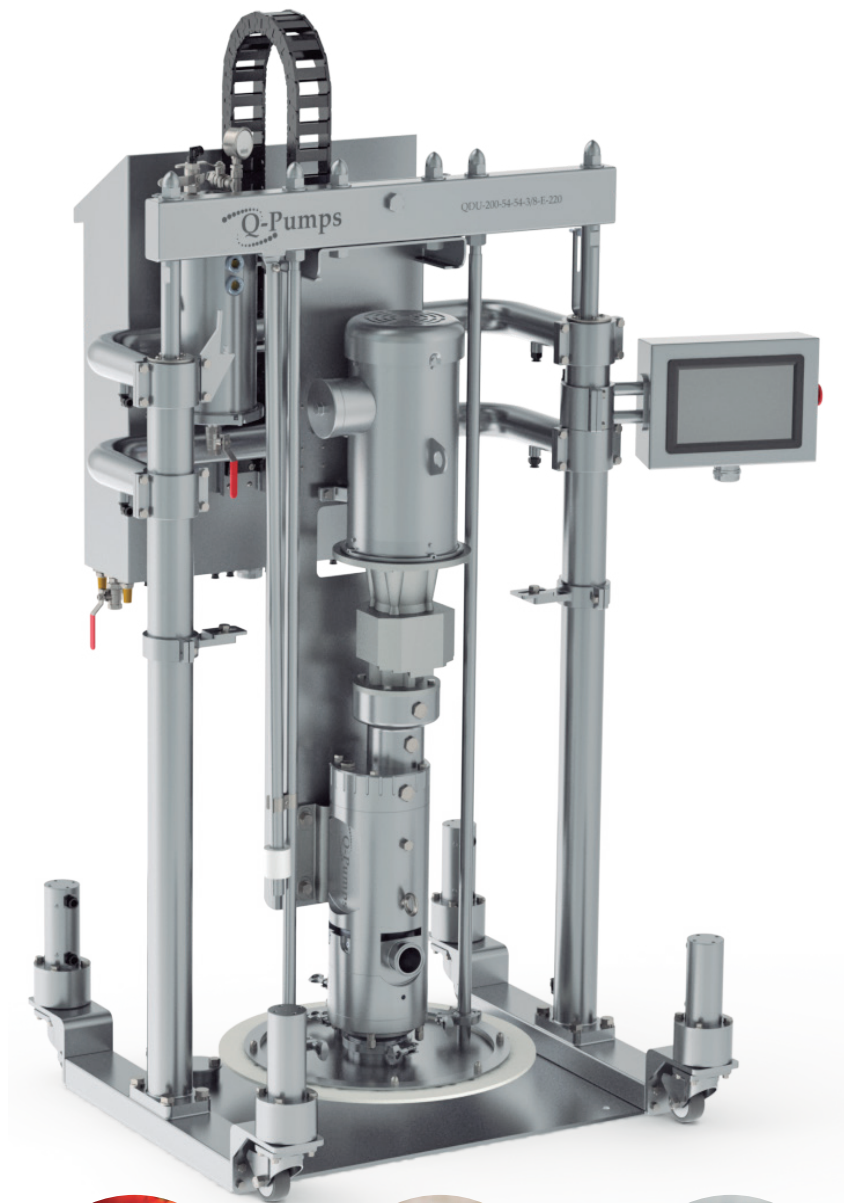

APPLICATIONS



OUR PRODUCTS



POSITIVE DISPLACEMENT PUMPS

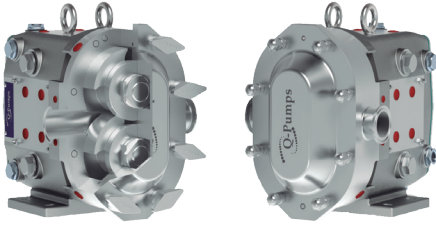

QP SERIES



QL SERIES

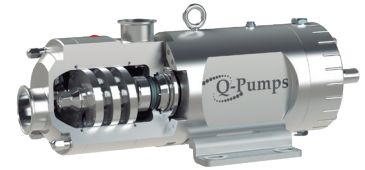

QTS SERIES

CENTRIFUGAL PUMPS



QC - QC+ SERIES

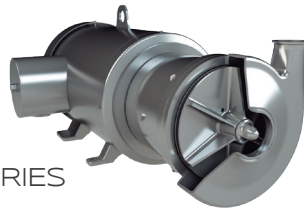

QWP SERIES



QIS SERIES

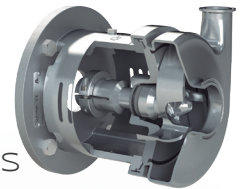

QCB+ SERIES

MIXERS AND BLENDEERS



QDB SERIES



QIM SERIES



QVM SERIES

DRUM UNLOADING SYSTEM

QDU SERIES



MORE THAN 24 YEARS MANUFACTURING CENTRIFUGAL PUMPS
TO SERVE THE CANADIAN AND UNITED STATES MARKETS



QC SERIES

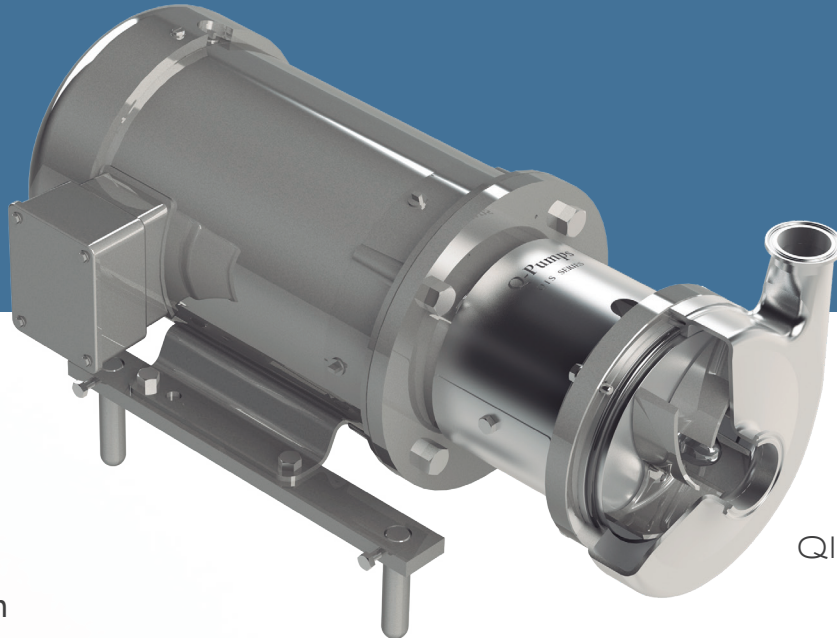

QIS SERIES

Q-Pumps, Inc.

1220 Bammel Rd.
Houston Tx. 77023
sales@qpumps.com

Distributed by:

The best pumping solutions for your sanitary applications | www.q-pumps.com