

Q-Pumps

QP1 Series

Sanitary Positive Displacement Pumps

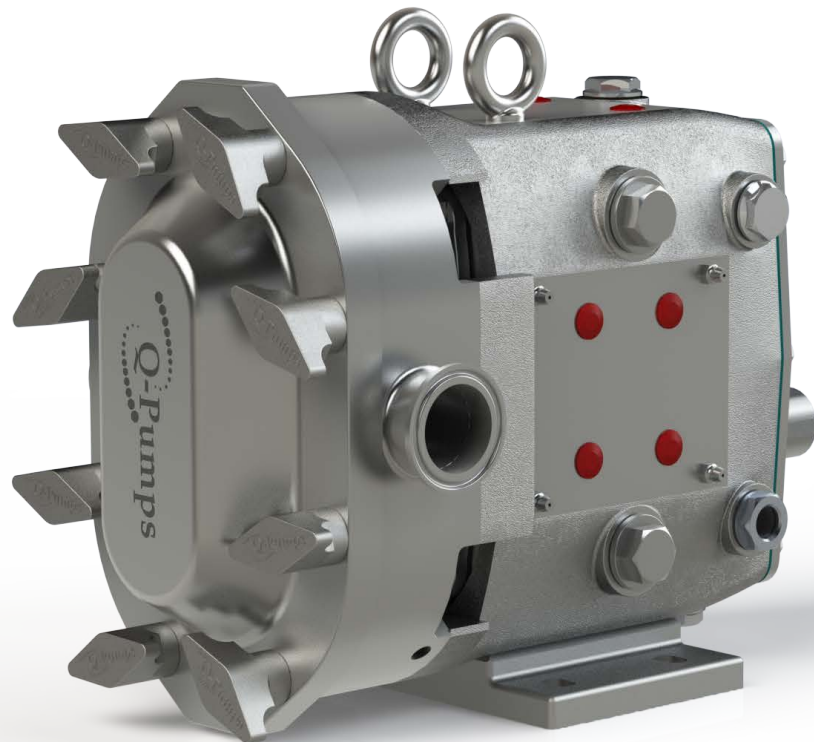

Installation and Maintenance Manual

Table of Contents

Introduction	3
Introduction	3
Q-Pumps Warranty	3
General Information	3
Shipping Damage or Loss	3
Receiving/Safety	4
Pump Receiving	4
Safety	4
Pump Information	5
Pump Information	5
Label Information	6
Installation	7
Installation	7
Base Arrangement	7
Piping and Connections	8
Check/ Isolation/ Relief Valves	9
Strainers and Gauges	10
Base Alignment	10
Pump Rotation	11
Final Installation	11
Maintenance	12
Maintenance	12
Pump Lubrication	12
Preventive Maintenance/ Inspection	13
Gear and Bearing Inspection	14
Annual Maintenance	15
Cleaning	15
Pump Disassembly	16
Seal Maintenance	17
Single O-Ring Seal	17
Double O-Ring Seal	17
Single Mechanical Seal	18
Double Mechanical Seal	19
Gear Case Maintenance	21
Disassembly	21
Assembly	23
Pump Assembly	28
Pump Clearances	29
Troubleshooting	30
Reconditioning Program	33

Introduction

To ensure the best results and service, please read and fully understand this manual prior to putting this pump into service. For any questions regarding operation, maintenance, or installation, please contact your Distributor or Q-Pumps. Q-Pumps contact information is as followed:

*Q-Pumps S.A. de C.V.
Acceso "A" #103, Fracc. Ind. Jurica
Querétaro, Qro. México, 76130
Phone: +52 (442) 218 4570 or +52 (442) 103 3100
Fax: +52 (442) 218 4577
Email: sales@qpumps.com*

Q-Pumps Company Warranty

Q-Pumps guarantees all of its manufactured products sold to be free from defects in material and craftsmanship for a period of one (1) year from the date of shipment. The warranty does not apply to products requiring repair or replacement due to what is deemed as normal wear and tear. Conditions arising from normal wear and tear include, but are not limited to, standard rotor wear, pump body wear, seal wear, bearing or gear wear. Accident, misuse, or improper maintenance also does not apply to the Q- Pumps warranty.

Q-Pumps assumes no liability for consequential, incidental or indirect, damages. And the purchaser, by acceptance of delivery, assumes all liability for the consequences of use or misuse by the purchaser, his employees, or others. Unless approved by Q-Pumps in advance, Q-Pumps will assume no field related expenses for service or parts.

General Information

Each QP1 pump is fully assembled, lubricated, and tested at the factory and shipped ready for use. Standard maintenance practices are outlined in this manual, for more information please refer to the Maintenance section starting on page 12. Following these guidelines will provide long lasting, trouble free service when the pump(s) is incorporated in a properly designed system.

If deemed necessary to return product under warranty, or for some other reason, contact Q-Pumps to receive a Returned Material Authorization (RMA) number to allow us to expedite this request as quickly as possible.

Shipping Damage or Loss

Upon receiving equipment that is damaged or lost in transit, immediately file a claim with the carrier. At time of pick-up, the carrier signed the bill of lading, acknowledging that they have received the product from Q-Pumps in good condition.

Pump Receiving

Q-Pumps covers all the pumps inlet and discharge ports prior to shipping, to ensure that foreign matter does not enter pump during shipment. If the protective covers are missing upon arrival, remove the pump cover and inspect to ensure it is free from contaminate before turning the shafts. It is important to make note of the pump serial number; this will assist in the process of ordering replacement parts and/or warranty claim. For more information regarding shipment damage or warranty, please refer to the Introduction/Warranty section in this manual.

Safety

IMPORTANT: Read and understand this manual BEFORE installation, operation or maintenance of the pump. Improper installation, operation or maintenance may result in severe injury or death. Equipment damage caused by user neglect will invalidate the pump warranty.

There are safety symbols used throughout this manual identifying safety concerns.



WARNING: Hazards or unsafe practices that COULD result in severe personal injury or death, and how to avoid them.

CAUTION: Hazards of unsafe practices that COULD result in minor personal injury or damage to product or property.

Pump Information

Pump Information

The design of the QP pump gear case allows for the shaft location to be universal in order to fit any system requirement. This can be seen in Figures 1 and 2:

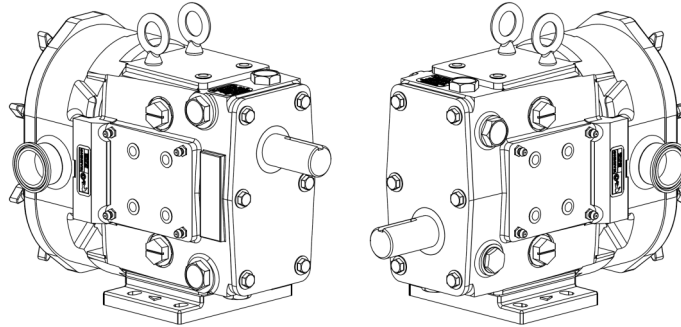

Figure 1: Shaft Mounts (Upper and Lower)

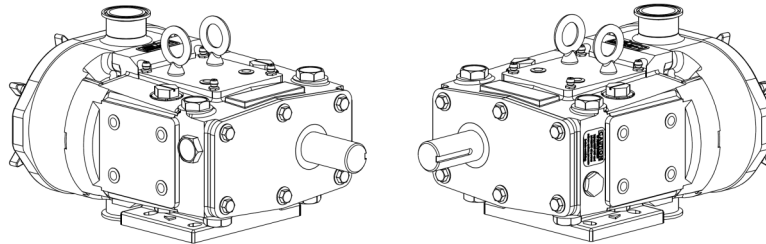

Figure 2: Shaft Mounts (Right and Left)

Table 1: Standard Operating Parameters

Model	Maximum Nominal Capacity		Displacement		Maximum Differential Pressure		Temperature Range		Standard Connection Size		Optional Connection Size		Maximum Speed	
	GPM	M ³ /hr	Gal. / 100 rev	Liters / rev	PSI	Bar	° F	° C	in.	mm	in.	mm	Rev/min	
QP1 6	6.0	1.3	0.8	0.030	200	14	-40° to 300°	-40° to 150°	1.5"	38	1"	25	800	
QP1 15	9.0	2.0	1.4	0.052	200	14			1.5"	38	-	-	-	700
QP1 18	17.0	3.8	3.0	0.110	200	14			1.5"	38	2"	51	51	600
QP1 30	36.0	8.2	6.0	0.230	200	14			1.5"	38	2"	51	51	600
QP1 60	90.0	20.4	15.0	0.580	200	14			2.5"	64	3"	76	76	600
QP1 130	150.0	34.1	25.0	0.960	200	14			3.0"	76	4"	102	102	600
QP1 180	230.0	52.2	38.0	1.450	200	14			3.0"	76	-	-	-	600
QP1 220	310.0	70.4	52.0	1.980	200	14			4.0"	102	-	-	-	600

Pump Information

Table 2: Rectangular Flange Model Operating Parameters

Model	Maximum Nominal Capacity		Displacement		Maximum Differential Pressure		Temperature Range		Rectangular Inlet (W x L)		Outlet		Maximum Speed
	GPM	M ³ /hr	Gal./100 rev	Liters / rev	PSI	Bar	° F	° C	inches	in.	mm	Rev/ min	
QP1 34	24.0	5.4	6.0	0.22	200	14	-40° to 300°	-40° to 150°	1.75 x 6.75	2"	51	400	
QP1 64	60.0	13.6	15.0	0.57	200	14			2.24 x 8.82	2½"	64	400	
QP1 134	100.0	22.7	25.0	0.96	200	14			2.97 x 9.25	3"	76	400	
QP1 224	200.0	45.4	52.0	1.97	200	14			3.87 x 11.00	4"	102	400	

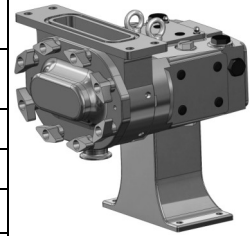

- For operating parameters that fall outside the standard values defined in Table 1 and Table 2, please contact the Engineering department at Q-Pumps. The contact phone number is +52 (442) 218 4570.
- Standard rotors operate within a temperature range of -40 °F to 200 °F. Hot clearance rotors operate at 180 °F to 300 °F. Consult Q-Pumps for questions on application factors such as temperature, operation speed and differential pressure.

Label Information



WARNING: Labels are installed on the pump at the factory to ensure proper warning to users. It is important not to remove these labels; doing so may result in injury.

The pump is installed with simple, but effective labels to help the customer better understand the QP1 pump. An identification plate is applied at the factory to help track the life of the pump. The customer should be aware of the pump's serial number and model number prior to contacting Q-Pumps with any concerns. These labels can be seen below in Figure 3:

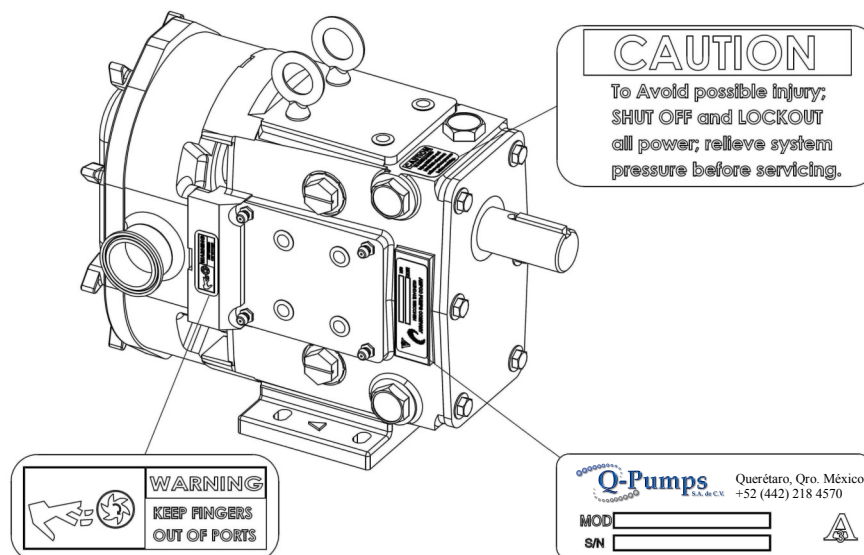

Figure 3: Important Label Information

Installation

Follow local codes and restrictions when installing the pump and piping system. The practices outlined in this manual are intended to ensure the most optimal performance of the pump.

Base Arrangement

The standard installation arrangement for a pump of this type consists of both the pump and drive unit mounted on the same base plate. Typical base plate arrangements consist of permanently fixed bases, bases with leveling and/or vibration isolation pads, bases with attached adjustable legs, or portable/wheeled bases. All base arrangements must be level during operation. Standard base configurations (base, pump, coupling, coupling guard, gear reducer, and motor) can be seen below in Figure 4.

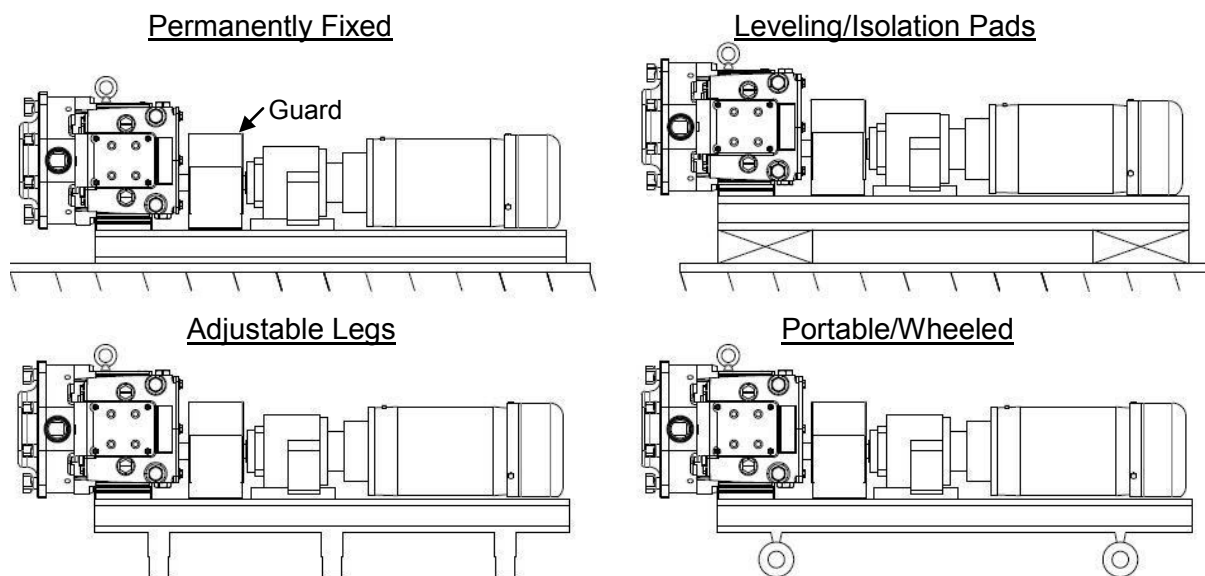

Figure 4: Base Layout Examples



WARNING: Guards must be installed to protect personnel from rotating parts and components. Failure to do so may result in injury. All complete base packages which consist of pump and drive units provided by Q-Pumps are sent with protective guards.

Piping and Connections

It is important to minimize forces imposed on the pump. This can be done by independently supporting the piping going to and from the pump. Excessive force applied to the pump can cause misalignment of internal parts which leads to the premature wear of rotors, bearings, and shafts. The use of hangers and pedestals on connecting pipes will help avoid such misalignment. Examples of such supports can be seen in Figure 5.

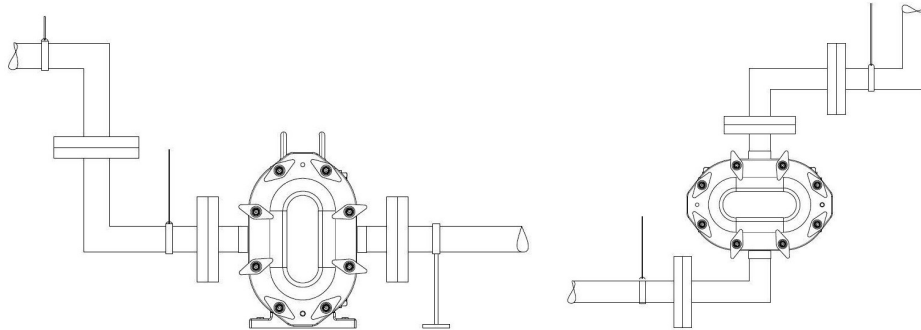

Figure 5: Piping Support Example

It is not recommended to weld custom fittings outside the factory. Shrinkage and warpage can occur to the pump housing which will affect the life and performance of the pump.

To prevent air pockets from entering the pump from the inlet, install the pump below the supply (Figure 6). This will help prevent air in the system by having constant product supply on the suction side. Sloping the piping on the inlet side away from the pump will prevent air pockets if the pump is installed above the supply (Figure 7).

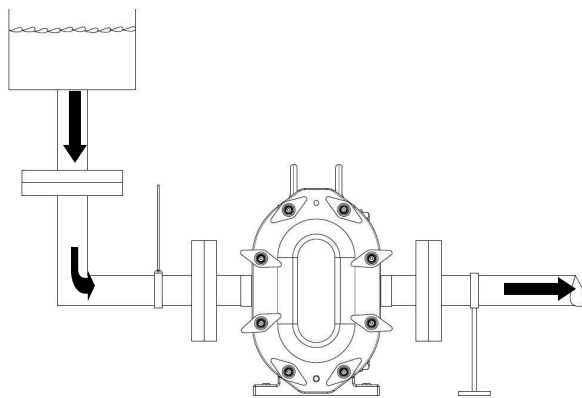

Figure 6: Correct Piping (Supply Above)

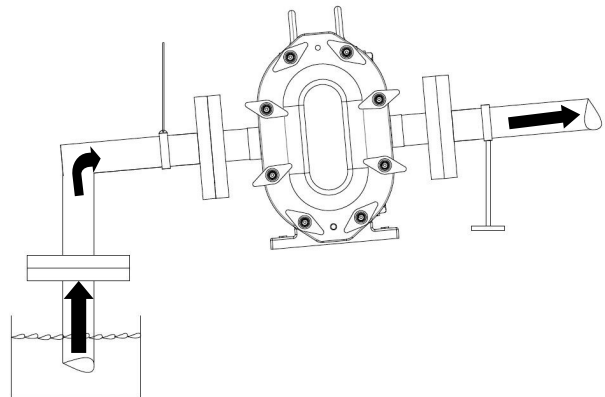

Figure 7: Correct Piping (Supply Below)

Installation

Check/ Isolation/ Relief Valves

Check valves should be used on the inlet side for any application when the product is lifted (Figure 8). This is to ensure a full inlet and is especially important with low-viscosity fluids. If the system has liquid under a vacuum, such as closed tank applications, it is important to have a check valve on the discharge side to prevent backflow during initial start-up (Figure 9).

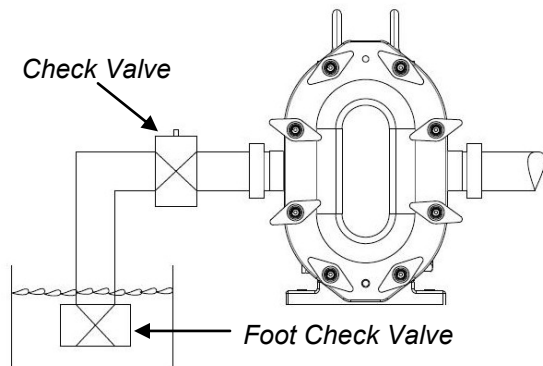

Figure 8: Check Valve (Inlet Side)

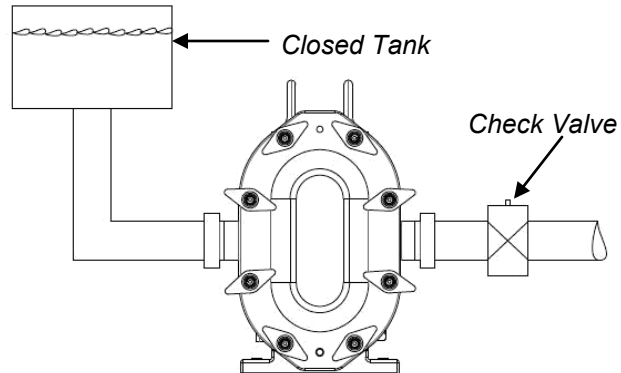

Figure 9: Check Valve (Discharge Side)

When shut down time is not possible, a bypass system may be installed with a backup pump in parallel series to allow production to continue while maintenance is performed on the down pump. Isolation valves may also be used on both the inlet and discharge sides of the pump to shut down the flow of product to the pump. This will allow for maintenance and removal of the pump without draining the entire system and risking the loss of product.



CAUTION: QP positive displacement pumps are designed with extremely tight tolerances allowing only low slip internally between rotors and pump housing. DAMAGE will occur if the pump is operated with discharge or inlet lines closed. DO NOT operate pump with lines closed.

In order to prevent damage to the pump, it is recommended a relief valve be installed on the pump's discharge side. The relief valve can either divert flow into a drain or back to the inlet side (Figure 10).

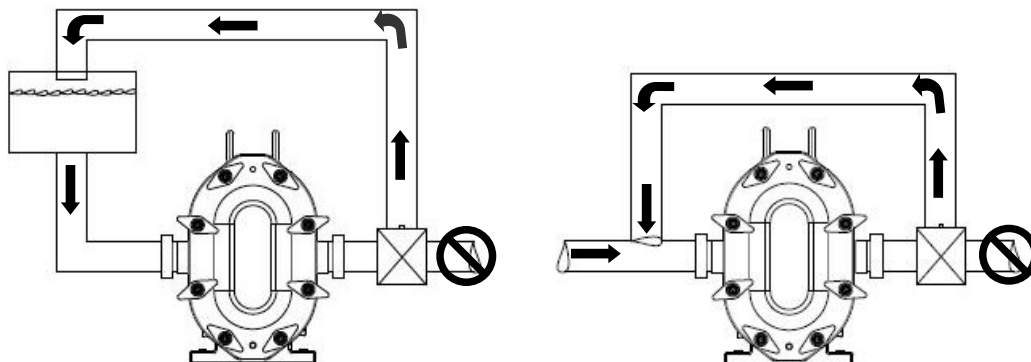

Figure 10: Relief Valve Examples

Strainers and Gauges

To prevent foreign matter from entering pump, strainers and magnetic traps should be used. It is essential to service strainers and traps regularly to prevent restriction of flow. To determine the performance of the pump, install pressure and vacuum gauges on the inlet and discharge piping (Figure 11).

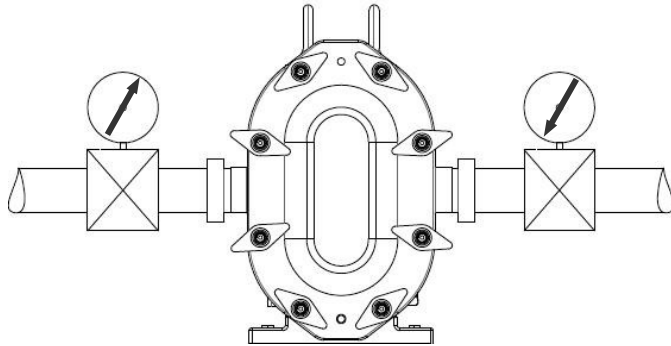

Figure 11: Proper Gauging

Proper Gauging Shows:

- Unusual pressure variations
- Indicates flow
- Changes in pump performance
- Variations in the system
- Differences in fluid viscosities

Base Alignment

Pump and base assemblies sent directly from factory are aligned prior to shipment. Assemblies must be checked once they are installed prior to operation. Misalignment may cause unnecessary wear and shorten the life of the pump.

To check the pumps coupling alignment start with checking the angular alignment by measuring the gaps between the couplings on both the pump and motor side (Figure 12, Angular Alignment). Shim the assembly accordingly so the gap is equal distance at all points. Next check the horizontal and vertical alignment of the coupling using a straight edge. Place the straight edge along the coupling to ensure that both sides are concentric with each other (Figure 12, Parallel Alignment).

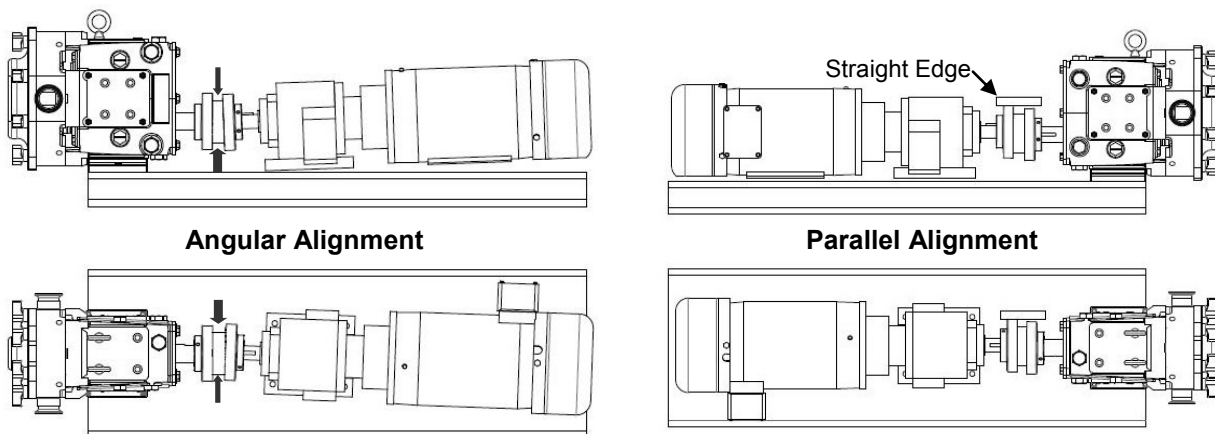

Figure 12: Check Alignment

Installation

Pump Rotation

It is important to check the direction of rotation (both on drive unit and pump) prior to connecting the pump to the drive. This will ensure correct product flow at start-up (Figure 13 and Figure 14). Also check that the pump turns freely and is free of any foreign contaminate. Install the pump and check to make certain all guards are in place.

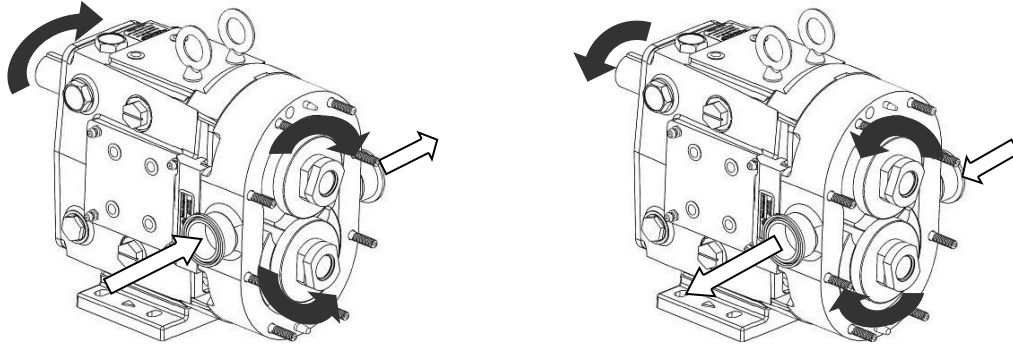

Figure 13: Top Drive Shaft

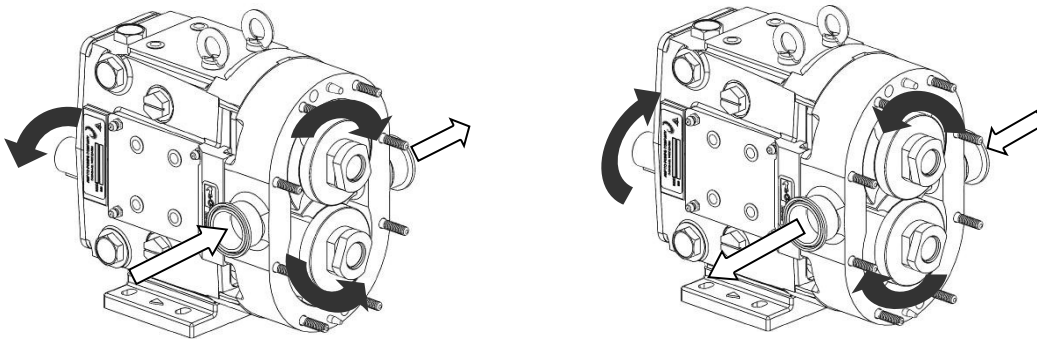

Figure 14: Bottom Drive Shaft

Final Installation

For pumps with double seals, connect seal flushing before operation. Operation of the pump without proper flushing will **damage** seal faces. Flushing connections are typically 1/8" female NPT with one side being the inlet and the other the discharge. Flush both top and bottom seals simultaneously (Figure 15). Flush flow rate should be 1/4 GPM. For high temperature applications flush flow may be increased to remove excess heat.

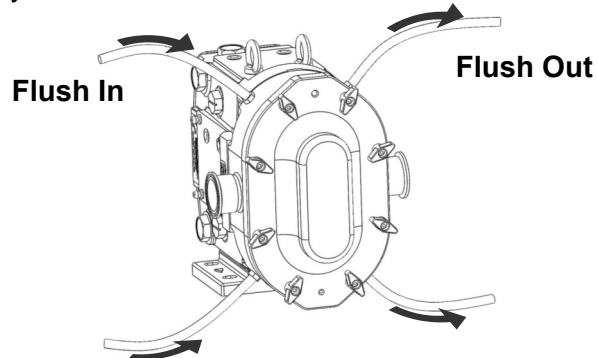

Figure 15: Proper Flushing for QP1 Double Seal

Maintenance



WARNING: Before attempting service on the pump or motor, DISCONNECT the energy source to the pump. This will help prevent accidental start-up and serious injury.

The QP1 pump is designed to be easily disassembled for cleaning and maintenance purposes. When performing maintenance on the pump it is important to inspect all wetted parts for standard wear and damage. For inspection instructions please see page 13. For rebuild information, see PD Pump Reconditioning Program details on page 33. Prior to disconnecting pump, shut off all inlet and discharge valves, drain the pump (rinse if necessary), and turn off all electrical supply to the pump (follow standard lock out procedures).

Pump Lubrication

Proper lubrication of gears and bearing is vital to the life of the pump. For pumps assembled on bases with a gear reducer and motor, please refer to the proper manufacturer manual for lubrication requirements. These manuals are sent with the pump from the factory. Important lubrication points can be seen in Figure 16.

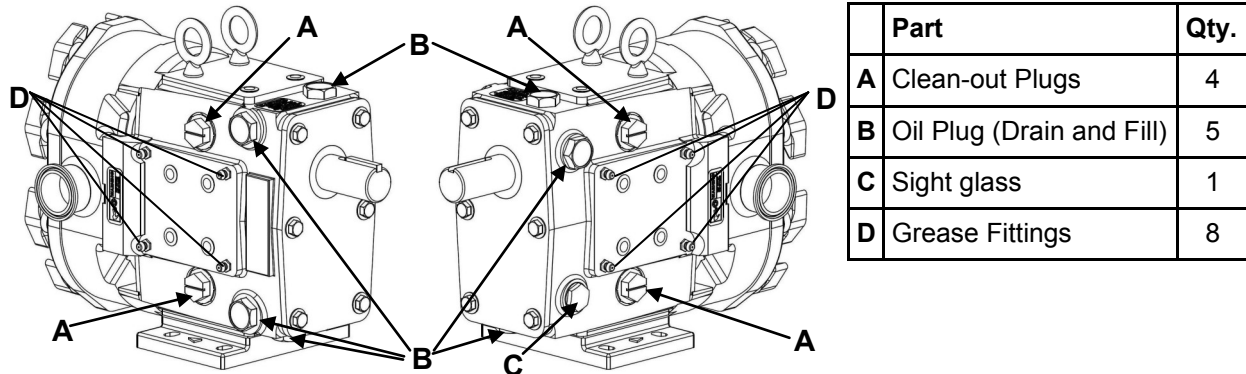

Figure 16: Lubrication Points

Both gears and bearing are shipped factory lubricated with grease and oil. The oil used to lubricate the gears should be changed every 500 hours with the quantities shown in Table 3. The bearings should be re-greased every 250 hours. Excessive grease may build up inside the gear case and should be cleaned out through the clean-out plugs shown in Figure 16, A.

Table 3: Oil Capacity (Gears)

QP1 Model	Top/Bottom Shaft	Side Mount
6,15,18	1.3 oz	3.3 oz
30, 34	2.0 oz	4.0 oz
60, 64	6.0 oz	9.5 oz
130, 134	6.0 oz	9.5 oz
220, 224	11 oz	20 oz
320, 323	17 oz	44 oz

Oil Specifications:

ISO Grade 320, SAE 140 or AGMA Number 6EP

Grease Specifications:

Halo-Guard FG-2, NSF H1 FOOD-GRADE, NLGI Grade No. 2

*Replacement oil and grease is available from Q-Pumps

Preventive Maintenance/ Inspection

While performing standard maintenance or cleaning, check for signs of damage or extreme wear. A simple inspection may show signs of a problem long before it becomes serious. Detection of such problems can avoid costly repairs and reduce down time. Remove the cover and inspect the rotor tips to ensure that there is no metal-to-metal contact between the rotors. Measure the clearance between the rotor tips as seen in Figure 17. The clearance should be equal on both sides. If contact is detected, rotors may require replacement.

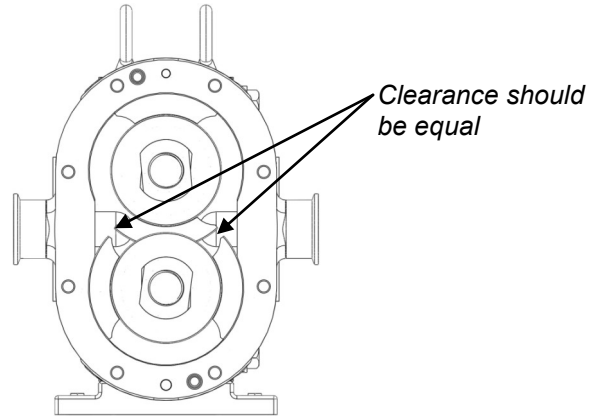

Figure 17: Clearance Between Rotor Tips

Inspect the shaft shoulder and splines (Figure 18) for wear and replace, if necessary.

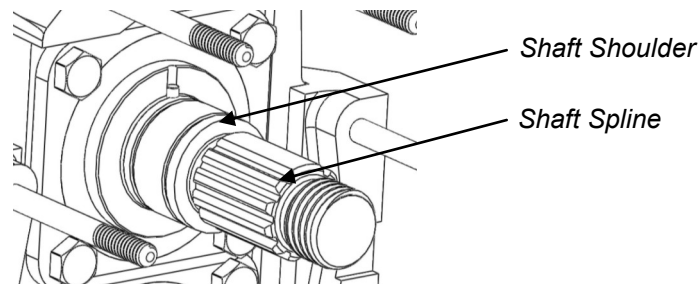

Figure 18: Shaft Inspection Points

Also, inspect the rotor hub (Figure 19) for wear and replace, if necessary. Rotor and shaft wear at these locations is caused by extended operation with loose rotor nuts.

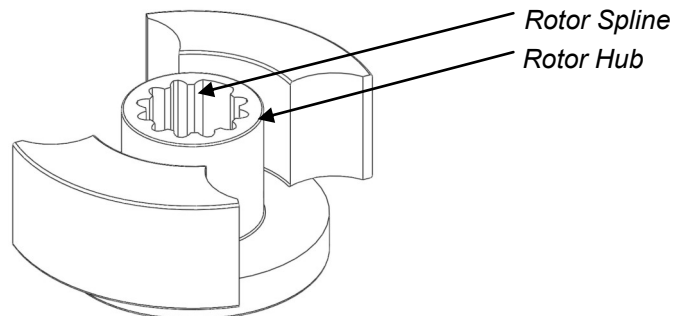

Figure 19: Rotor Inspection Points

Gear and Bearing Inspection

While the fluid end is disassembled feel for gear backlash (play in between the gears) by rotating either shaft. Once turning has started the other shaft must engage (Figure 20). If gear backlash is present remove the gear casing cover (drain oil first, see page 21 for disassembly information) and check for wear around the gear teeth. Once the cover is removed check for loose gears and gear teeth wear. If evidence of gear teeth wear is present, replacement is recommended. If gears are loose, check the shaft key and keyway, either may require replacement.

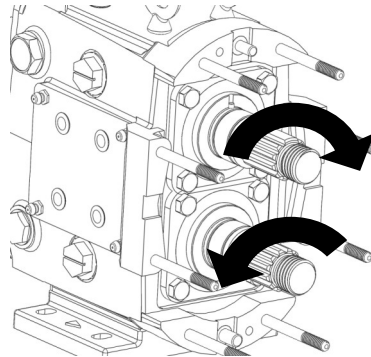

Figure 20: Check for Gear Backlash

Next, check the condition of the bearings. Do this by applying force in an up and down motion by hand on both shafts (Figure 21). Also check for any horizontal movement by pushing and pulling on the shaft. If any movement is felt the bearing may need replacing. If disassembly of the entire gear case is required, please refer to page 21 for instructions.

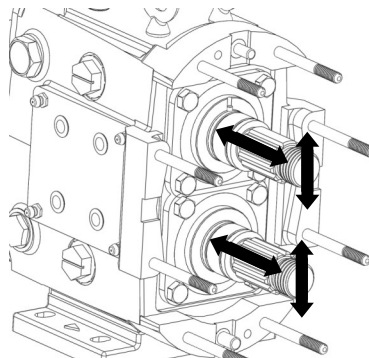

Figure 21: Check for Bearing movement

Annual Maintenance

It is important to perform an annual maintenance check of the pump in addition to the preventative maintenance procedures listed on pages 13 and 14. Annual maintenance practices are as follows:

- Check the gear case bearings by measuring the shaft's radial movement with a dial indicator (Figure 22, A). If the movement is greater than or equal to the rotor to body clearance found on page 29 (Table 8) the bearings should be replaced.
- Remove the gear casing cover (See page 21 for disassembly information) and inspect the gears for wear and damage (Figure 22, B). Also check for backlash and looseness.
- Inspect the rotors for signs of wear and stress cracks around the areas defined in Figure 22, C. Replace, if necessary.
- Check the pump clearances detailed on page 29 to determine pump wear. Pump wear can be compensated by increasing pump speed.

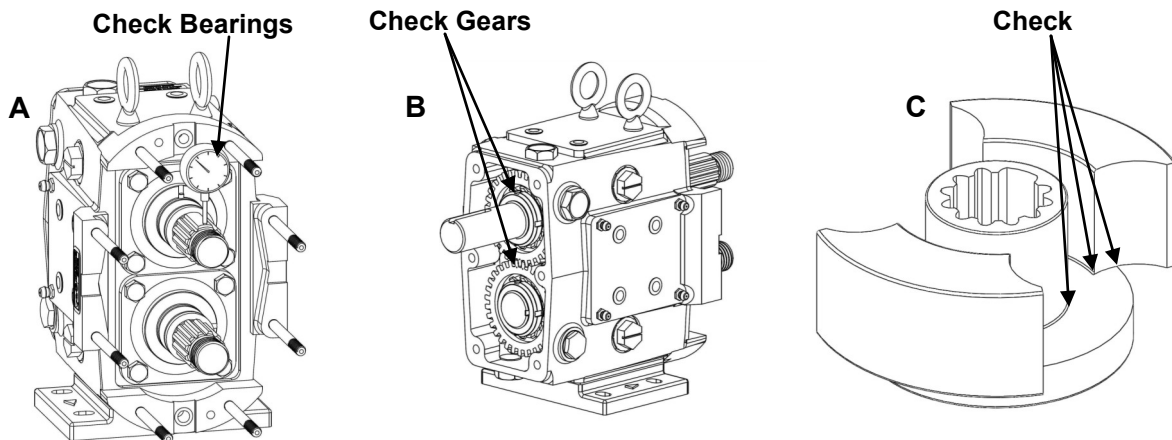

Figure 22: Annual Maintenance Checks

Cleaning

The QP1 pump is specifically designed for COP (Clean Out of Place) practices. All wetted parts are designed and manufactured to be acceptable by 3A Sanitary Standards. The body, rotors and seals can be easily disassembled and cleaned simply by removing the cover and rotor nuts. Pump disassembly information begins on page 16.

Once the fluid end is disassembled, follow standard practices for cleaning the product being pumped. It is important not to use abrasive cleaning tools and chemicals. Wire brushes or pads will physically damage metal and seal parts. Also, pump parts should not be exposed to harsh acids for longer than necessary. Once the parts have been removed from a cleaning solution, rinse so no residual deposits remain. Acids and cleaning solutions can be harmful. Take necessary steps to prevent bodily harm.

Pump Disassembly



WARNING: Before servicing pump or motor, DISCONNECT the energy source to the pump. This will help prevent accidental start-up and serious injury.

CAUTION: SHUT OFF product supply to the pump and drain the pump before disconnecting piping and disassembly.

1) Start by removing the cover wing nuts using a soft mallet to loosen (Figure 23). During disassembly place all parts on a clean, protected surface with finished surfaces and seal faces facing up.

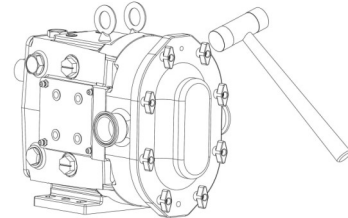

Figure 23: Removing Cover Wing Nuts

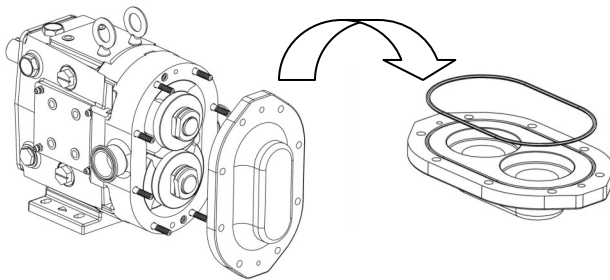

Figure 24: Removing Cover and Cover O-ring

2) Slide the cover off. If the cover is stuck to the pump body, use the soft mallet and tap the edges of the cover to break it loose. **DO NOT** use a screw driver or pry bar to break open the cover. Remove the cover o-ring and discard it, as it should be replaced (Figure 24).

3) Remove the rotor jam nuts using the wrench provided by Q-Pumps (Figure 25). Remove one at a time, by striking wrench with a soft mallet to break loose then turning counter clockwise. The nuts are made of a non-galling alloy to prevent from locking up on the shaft.

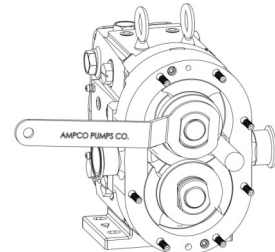

Figure 25: Removing Rotor Jam Nuts

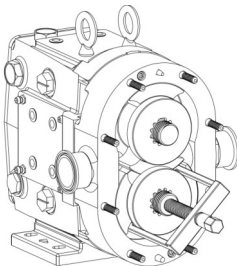

Figure 26: Removing Rotors (Gear Puller)

4) Remove the rotors by orientating them perpendicular to each other and then pulling them out. It is important to be cautious with the rotors so that they are not damaged in any way. If rotors are difficult to remove, use a nylon or wood lever to pry them out without damaging the body or the rotors. If needed, use a gear puller in orientation shown in Figure 26 and handle with caution.

5) Remove the two body hold down bolts using the appropriate driver. Then pull the pump body off by sliding it along the studs (Figure 27). If the body is stuck, use a soft mallet to tap the body. Inspect the body for excessive wear, clean, and continue on to seal maintenance. It is important to reassemble the pump body back onto the original gear case because the shafts are shimmed for that particular body.

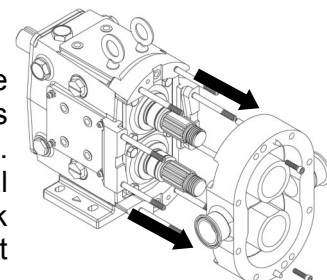

Figure 27: Removing Pump Body

Seal Maintenance

Single O-Ring Seal

Disassembly: The single o-ring seal option consists of two shaft sleeves and four o-rings (Figure 28). Remove the body o-rings using the tool provided by Q-Pumps (discard o-rings). Slide the shaft sleeves off the shafts and inspect for damage. Do not re-use sleeves that are damaged (sleeve surface grooved or scratched). Remove shaft o-rings and discard them.

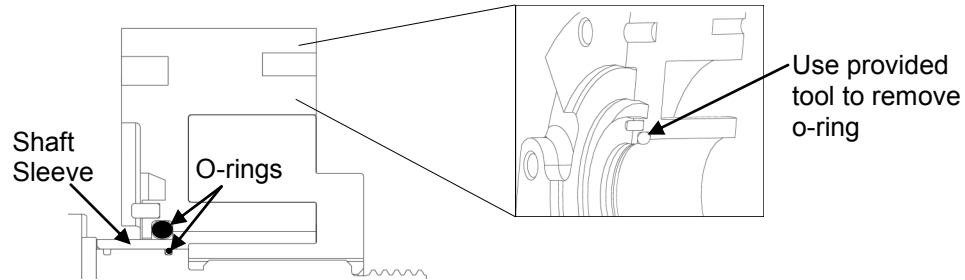

Figure 28: Single O-Ring Seal (Top Shaft)

Assembly: Clean both shaft ends and the body before assembling. Apply a light film of lubricant to NEW o-rings and insert them on the shafts (slot closest to splines) and into the body. Slide the shaft sleeves onto the shafts until it seats on the shaft shoulder. Shaft sleeves will either have prongs or be slotted and it is vital that the drive pin on the shaft fits between the sleeve prongs/slot (Figure 29). See Pump Assembly on page 28 to continue.

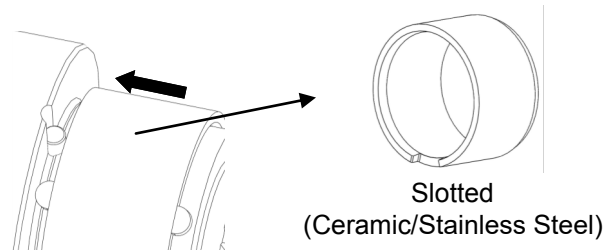

Figure 29: Single O-Ring Seal Assembly

Double O-Ring Seal

Disassembly: The double o-ring seal consists of two shaft sleeves, two o-ring carriers, and eight o-rings (Figure 30). Remove the o-ring carriers from the back of the pump body and discard the o-rings (Figure 30). Remove the body o-rings using the tool provided by Q-Pumps (discard o-rings). Slide the shaft sleeves off the shafts and inspect for damage. Do not re-use sleeves that are damaged (sleeve surface grooved or scratched). Remove shaft o-rings and discard them.

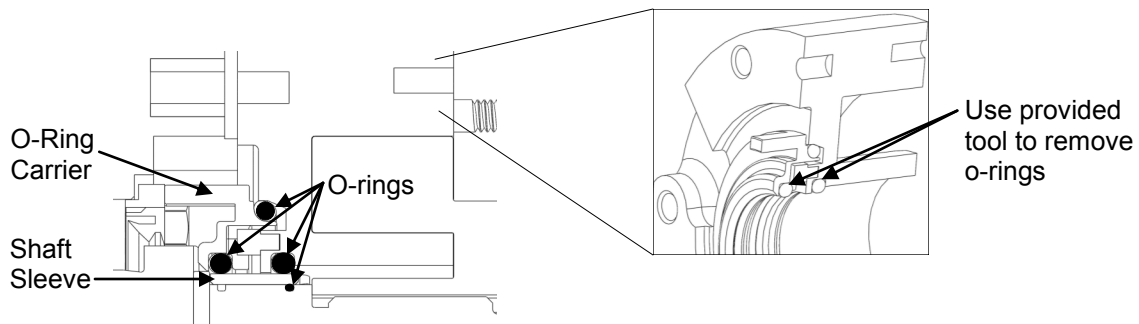

Figure 30: Double O-Ring Seal (Top Shaft)

Seal Maintenance

Double O-Ring Seal, Continued

Assembly: Clean both shaft ends and the body before assembling. Apply a light film of lubricant to NEW o-rings and insert them on the shafts (slot closest to splines), in the carriers and into the body. Slide the shaft sleeves onto the shafts until it seats on the shaft shoulder (Figure 29). Shaft sleeves will either have prongs or be slotted and it is vital that the drive pin on the shaft fits between the sleeve prongs/slot. Install the o-ring carriers into the back of the body making sure that the pin in the body and the slot on the carrier are lined up (Figure 31). See Pump Assembly on page 28 to continue.

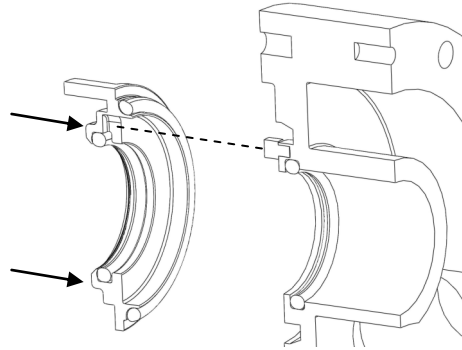

Figure 31: Double O-Ring Seal Assembly

Single Mechanical Seal

Disassembly: The single mechanical seal option consists of two mechanical seal sets (seal seat and stationary seal), two wave springs and four o-rings (Figure 32). Remove the stationary seals from the back of the body and inspect for chipping, scratches or any evidence of cracks on the seal face. Remove the body o-rings using the tool provided by Q-Pumps (discard o-rings). Remove the seal seats (rotating seals) from shafts and inspect for damage. If any of the seals are damaged do not re-use them. Remove shaft o-rings and discard.

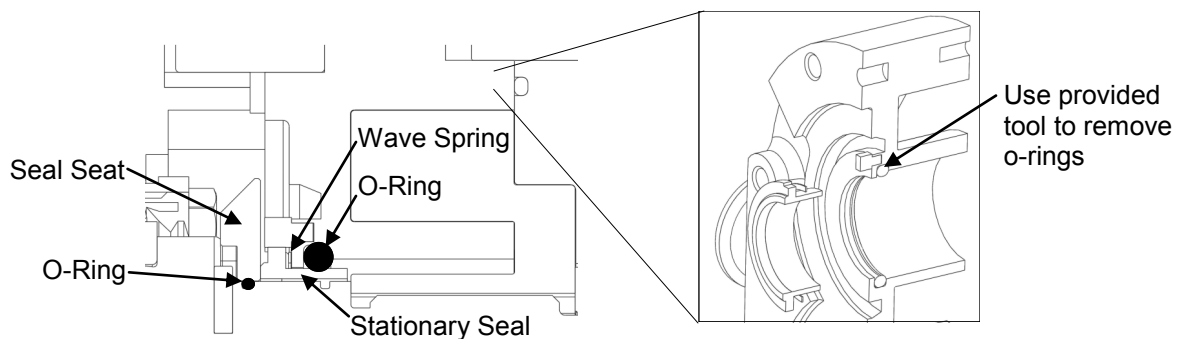

Figure 32: Single Mechanical Seal Disassembly

Seal Maintenance

Assembly: Clean both shaft ends and the body before assembling. Apply a light film of lubricant to NEW o-rings and insert them on the shafts (slot furthest from splines), and into the body. Slide the seal seat onto shaft by pushing it against the shaft shoulder making sure to align the slot on the seal seat to the drive pin on the shaft (Figure 33). Place the wave springs onto the stationary seals and install them into the back of the body making sure the slot on the seal lines up with the pin on the back of the body. Make sure all seal faces are clean. See Pump Assembly on page 28 to continue.

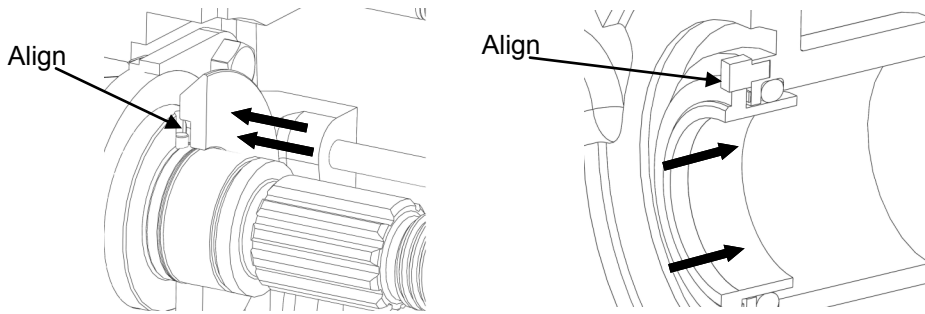

Figure 33: Single Mechanical Seal Assembly

Double Mechanical Seal

Disassembly: The double mechanical seal option consists of two mechanical seal sets (seal seat, inner and outer stationary seal), two wave springs and six o-rings (Figure 34). Remove the outer and inner seals from the back of the body and inspect them for chipping, scratches or any other evidence of cracks on the seal face. Remove the body o-rings using the tool provided by Q-Pumps (discard o-rings). Remove the seal seats (rotating seals) from shafts and inspect for damage (previously described). If any of the seals are damaged, do not re-use them. Remove shaft o-rings and discard them.

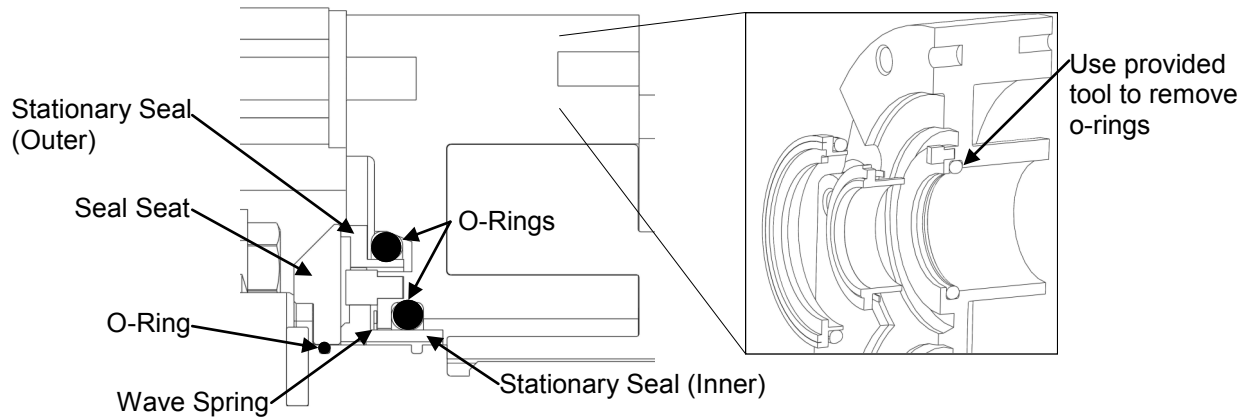

Figure 34: Double Mechanical Seal Disassembly

Seal Maintenance

Double Mechanical Seal Continued

Assembly: Clean both shaft ends and the body before assembling. Apply a light film of lubricant to NEW o-rings and insert them on the shafts (slot furthest from splines), into the body and on to the outer seals. Slide the seal seat onto shaft pushing against the shaft shoulder making sure to align the slot on the seal seat to the drive pin on the shaft (Figure 35). Place the wave springs onto the stationary seals and install them into the back of the body making sure the slot on the seal lines up the pin on the back of the body. Insert the outer seal (with o-rings) into the back of the body. Make sure all seal faces are clean. See Pump Assembly on page 28 to continue.

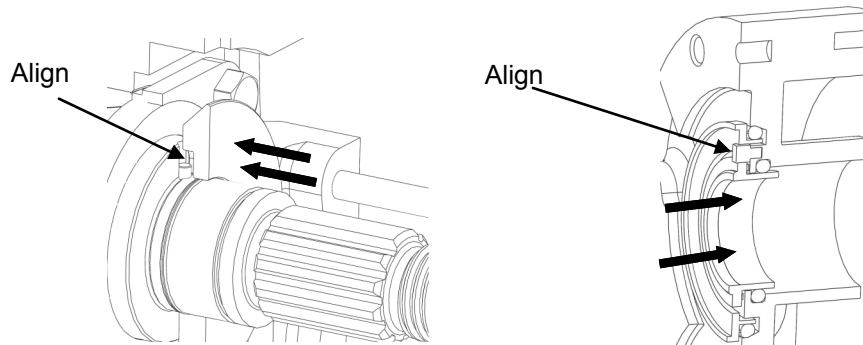

Figure 35: Double Mechanical Seal Assembly

Gear Case Maintenance



WARNING: Before servicing pump or motor, DISCONNECT the energy source to the pump. This will help prevent accidental start-up and serious injury.

CAUTION: SHUT OFF product supply to the pump and drain the pump before disconnecting piping and disassembly.

Disassembly

1) Remove the pump head as described on page 16 (Pump Disassembly). Remove the bottom oil plug and drain the oil from the gear case (remove oil fill plug for faster drain). Remove the six hex head cap screws and washers from the gear case cover and slide the cover off the drive shaft (Figure 36). If the cover is stuck, use a soft mallet to tap around the edges until it breaks free. Using a straight edge remove the liquid gasket used to seal the cover to the gear case. Remove and discard the oil seal from the cover using an arbor press.

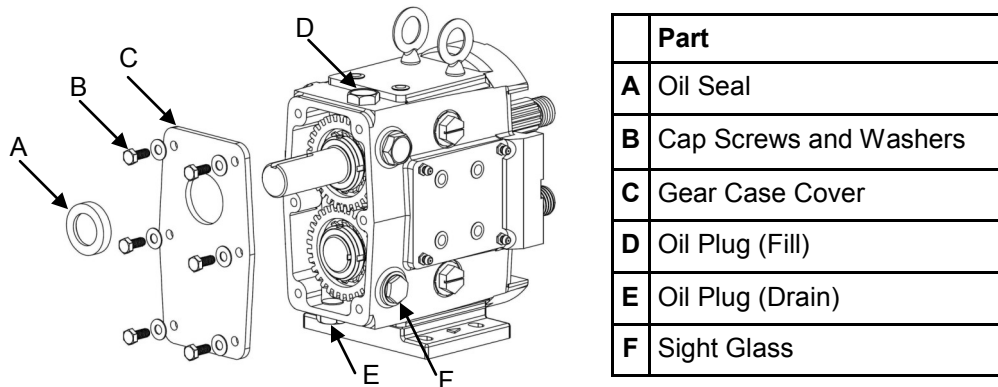

Figure 36: Gear Case Disassembly (Gear Case Cover)

2) Using a hammer and a punch, bend the tabs straight on the lock washers (Figure 37). Use a wedge (wood or plastic) to keep the shafts from turning while removing the lock nuts (Figure 38). Using a spanner wrench or the nut removal tool (available from Q-Pumps), remove the gear lock nuts. Slowly remove the gears from the shafts. Remove the gear keys and gear spacers from the shafts.

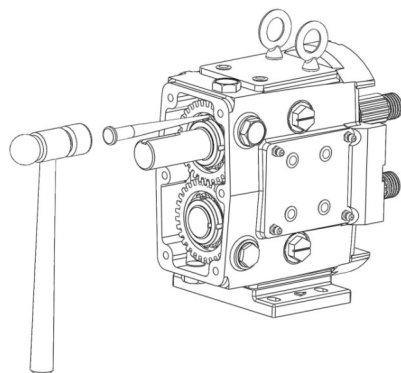

Figure 37: Bending Tabs on Lock Washers

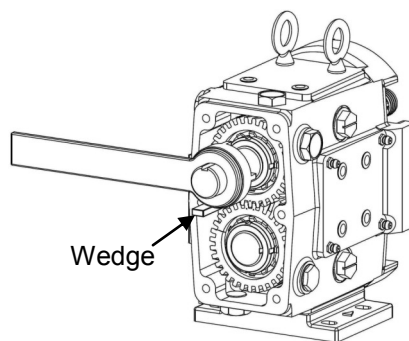

Figure 38: Removing Lock Washers

Gear Case Maintenance

3) To prevent damage to the shafts, wrap the splines and rotor nut threads with tape (Figure 39, A). Any damage to the splines or threads may require the shaft be replaced. Remove the cap screws holding the bearing retainers in place and slide both bearing retainers off the shaft (Figure 39, B). If they are stuck, use a flat head screw driver as a wedge to pry them from the gear case or leave them in place and when the shafts are removed they will press off with the shafts. Using a straight edge, remove the liquid gasket used to seal bearing retainer to the gear case.

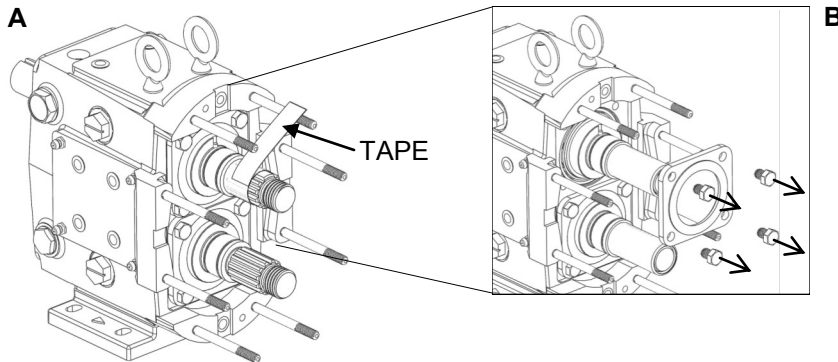

Figure 39: Tape Shafts and Remove Bearing Retainers

4) Set the gear case in a press with the fluid end side facing down (Figure 40). Use a wooden block to protect the shafts from hitting the ground when pushed out. Once the protective block is in place push the shafts out of the gear case. Reference Table 4 for the required force (in tons) needed to press the shafts out of the gear case.

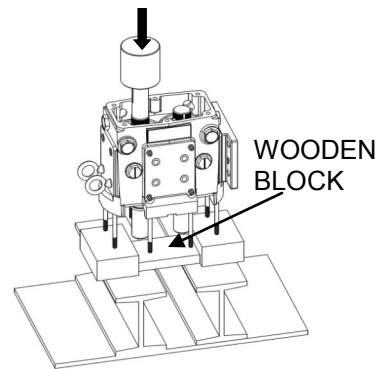

Figure 40: Pressing Shafts From Gear Case

Table 4: Required Force to Remove/Install shafts

QP1 Model	6, 15, 18	30, 34	60, 64, 130 134	220, 224	320,323
In (Tons)	.25	.25	.50	.50	.50
Out (Tons)	.50	.50	1.00	1.00	1.00

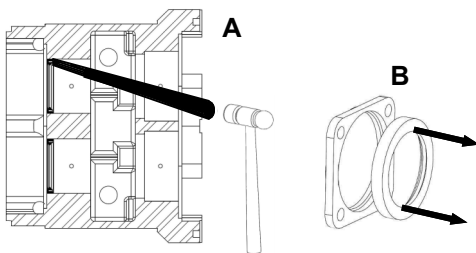

Figure 41: Removing Oil Seals

5) Remove the shaft shims making sure to correctly label which shaft they came from and from out of which shaft bore they came. If the shafts are to be reused, they will need to be reinstalled with the original shims. Failure to do so could result in damage and misalignment in the pump body. Remove and discard the rear oil seals from the back of the gear case. Use a long, non-metallic rod and a soft mallet to punch the seal out from the front side (Figure 41, A). Remove and discard the front bearing seals from the bearing retainers by pressing them out (Figure 41, B). Clean the bearing retainers as they will be reused. Clean excess grease and sludge inside of the gear case before reassembling.

Gear Case Maintenance

6) Using a press and a V-block, remove the front and rear bearings along with the bearing spacer. To prevent damage to the shafts make sure that both ends are protected (Figure 42). Reference Table 5 for the required force (in tons) needed to press the bearings off the shafts.

Table 5: Force Required to Press Bearings

QP1 Model	Front Bearings		Rear Bearings	
	On (Tons)	Off (Tons)	On (Tons)	Off (Tons)
6, 15, 18	.50	1.00	.50	1.00
30, 34	.50	1.00	.50	1.00
60, 64, 130,134	2.00	5.00	3.00	5.00
220, 224	5.00	15.00	5.00	15.00
320, 323	5.00	20.00	5.00	20.00

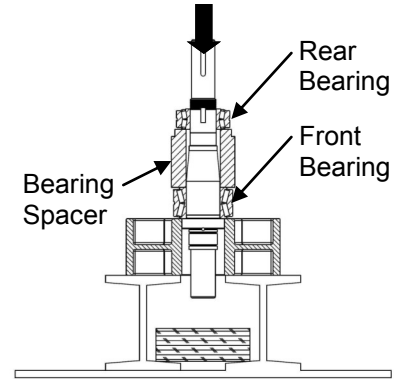

Figure 42: Removing Bearings and Sleeve From Shaft

Assembly

1) Clean all reusable parts prior to reassemble. Apply a light coat of lubricant on the shaft area where the front bearing will sit. Position the shaft upright in the press with the splines facing down (Figure 43, Drawing 1). Open the new front bearing assembly and be sure not to interchange any parts. All bearings are manufactured as sets and assembled to have a precise overall length. Place the front bearing over the shaft along with the bearing spacer (Figure 43, Drawing 2). Make sure the bearing and spacer are aligned before pressing them on. Reference Table 5 for the required force (in tons) needed to press the bearings on to the shafts. Using a sleeve that rests on the bearing spacer and rides over the shaft, press the bearing on until it seats against the shaft shoulder. A shim can be used to ensure that the bearing is fully rested on the shaft shoulder (Figure 43, Drawing 3).

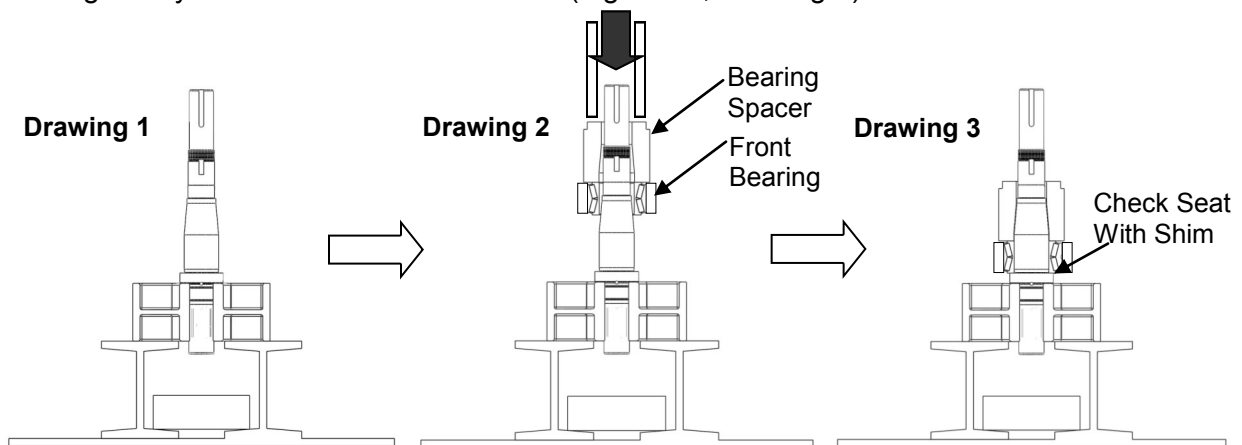

Figure 43: Pressing Front Bearing onto Shaft

Gear Case Maintenance

2) Single ball bearings are used for the rear bearing in models QP1 6, QP1 15, QP1 18, QP1 30, and QP1 34 and will require a light press to install. Tapered roller bearings are used for all other models and will be pressed on similar to the front bearings.

- For pump models with single ball bearings apply a light coat of lubricant on the shaft. Open the new rear bearing assembly and place it over the shaft above the bearing spacer with the shielded side of the bearing facing the spacer (Figure 44, Drawing 1). Press the bearing on pressing only on the inner race.
- For pump models with tapered roller bearings, apply a light coat of lubricant on the shaft. Open the new rear bearing assembly and do not interchange any parts. Place the rear bearing over the shaft above the bearing spacer (Figure 44, Drawing 2). Reference Table 5 for the required force (in tons) needed to press the bearing onto the shaft. Using a sleeve that rests on the inner cone of the bearing and rides over the shaft, press the bearing on until it seats against the spacer.

Make sure the bearing is rested on the bearing spacer using a shim (Figure 44, Drawing 3).

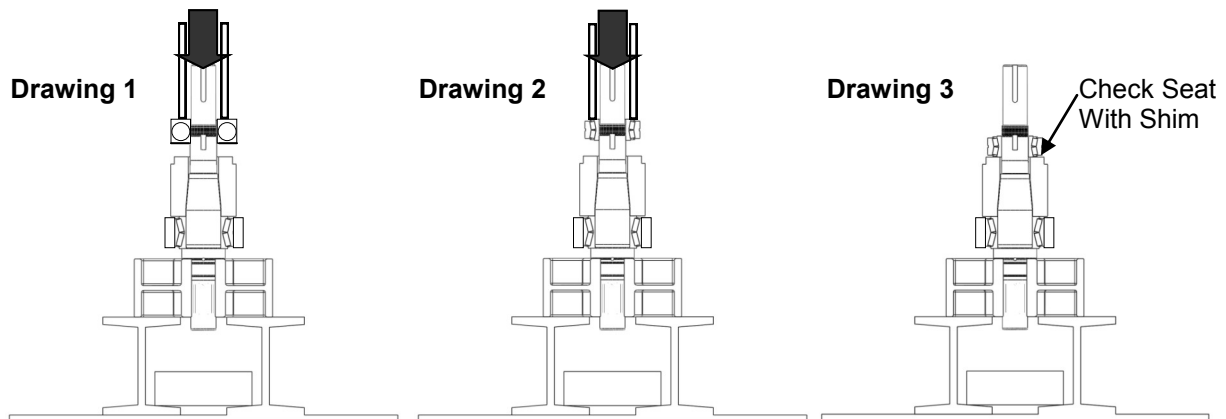

Figure 44: Pressing Rear Bearing onto Shaft

3) Shims located on the shaft behind the front bearing control the backface clearance of the pump; the space between the body and the rotor. If neither the shafts or bearings are being replaced, use the shims (if properly marked) removed at disassembly and reuse making sure they are installed in the correct bores. If replacing shafts or bearings, a process of calculating the required shims, is necessary. Use Figure 45 and the following equation to calculate. To find the correct backface clearance see Table 8, page 29.

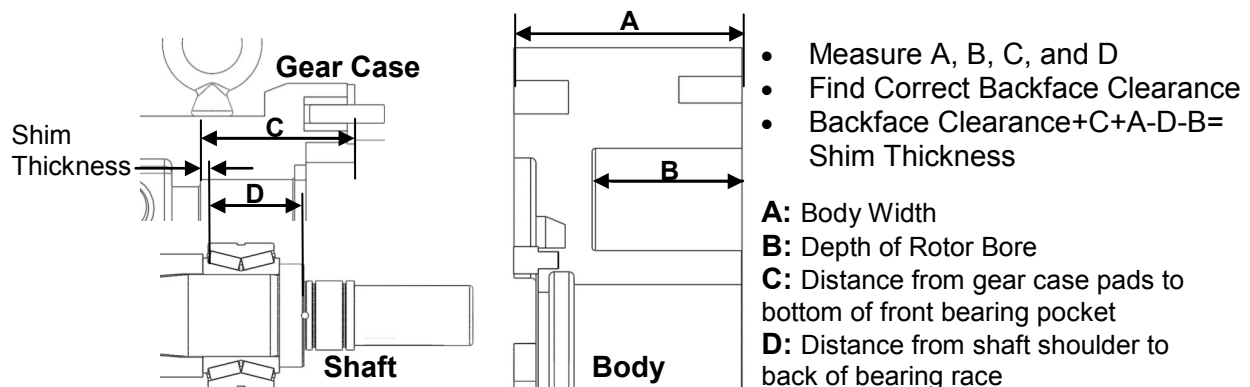

Figure 45: Calculating Shims

Gear Case Maintenance

4) Set the gear case on a press with the fluid end side facing up. Place the required thickness of shim stock so it sits on the shoulder of the front shaft bore of gear case. Apply lubricant to the outside of the bearings. Place shaft assembly (one shaft at a time) in the gear case with the spline end facing up. Making sure that the drive and the short shafts are in the correct bores, press the shafts into gear case until bearings are fully seated (Figure 46). See Table 4 on page 22 for the required force.

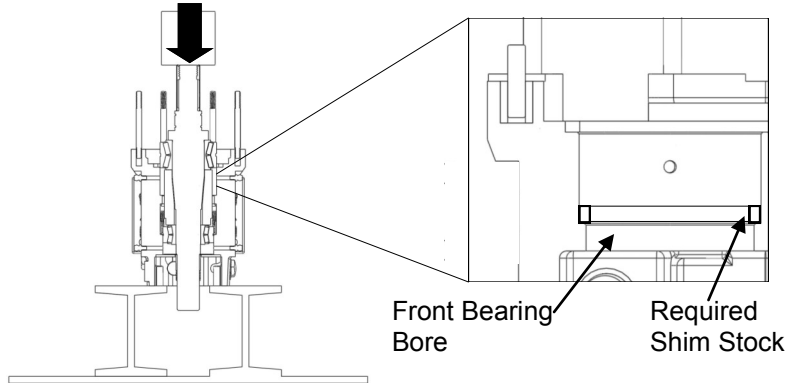

Figure 46: Pressing Shafts into Gear Case

5) Once the shafts are pressed into the gear case, install the bearing retainers to hold the shafts in place temporarily (do not install liquid sealant). Ensure there is proper clearance between the retainer and the gear case, as seen in Figure 47. Place the body on the gear case, making sure it is seated correctly. Assemble the rotors into the body and tighten down using the jam nuts. Measure dimensions A, B, and C seen in Figure 48 and refer to Table 8 (page 29) to verify the clearances. If clearances are not correct, the shafts must be removed and the shims will need to be adjusted. If the clearances are correct remove the rotors and body.

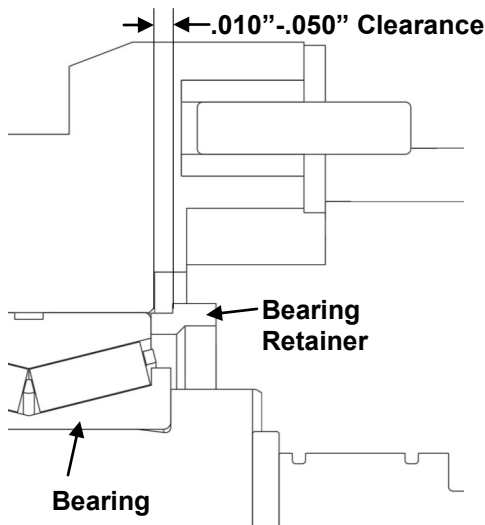

Figure 47: Bearing Retainer Clearance

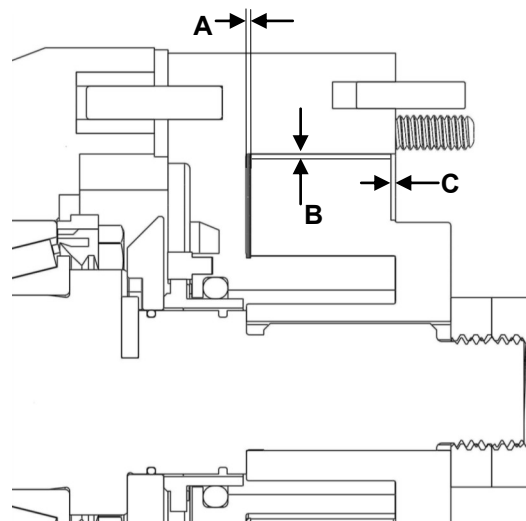

Figure 48: Important Clearances

Gear Case Maintenance

6) Once the correct backface clearance is achieved, fill all bearings with grease through the fittings on the mounting pads until grease is noticeable around the bearing assemblies. The shafts should be rotated during this initial greasing to distribute the grease evenly. Apply a light film of lubricant to the inside and outside diameters of the oil seals and install them into the bearing retainers. Apply a silicone sealant to the outside flanges on the bearing retainer (Figure 49). Once the silicone sealant is applied, install the bearing retainers onto the gear case.

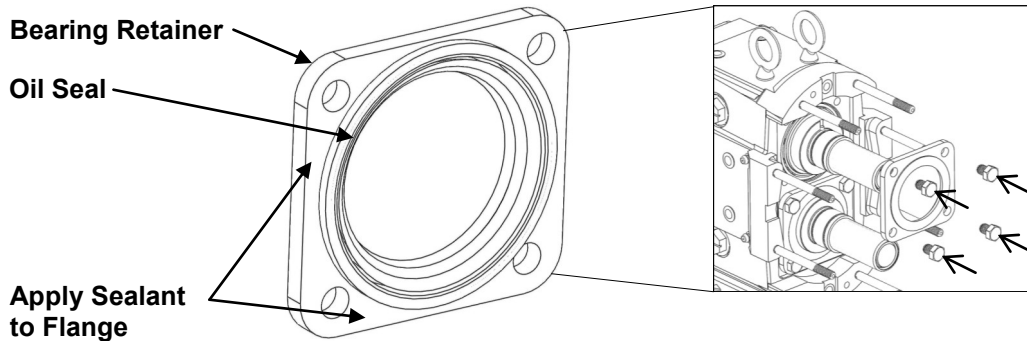

Figure 49: Bearing Retainer Installation

7) Apply a light film of lubricant to the inside and outside diameters of the rear oil seals and install them into the back of the gear case with the spring side facing outward toward the gear. Install the gear spacers onto the shaft and place the gear keys into the shaft key slots (Figure 50).

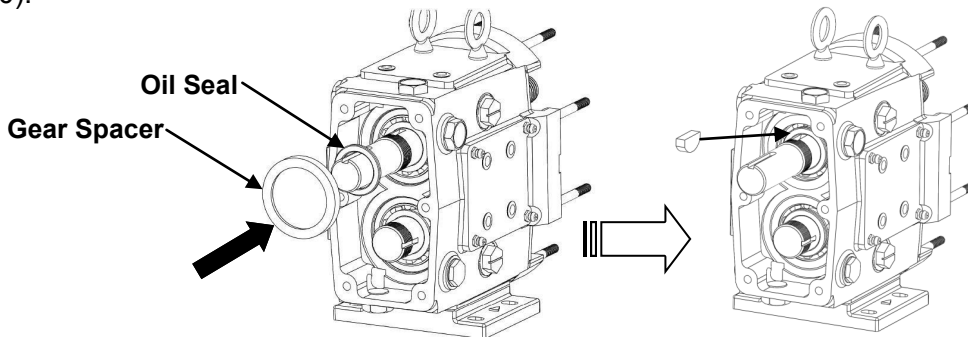

Figure 50: Rear Oil Seal and Gear Key Installation

8) Once the gear keys are installed, orientate the shafts so that the keyways on the drive shaft are pointing in the 12 o'clock direction (Figure 51, A). Slide the right-handed gear with the single punch mark onto the drive shaft. Slide the second gear with two punch marks on the short shaft. To time the gears align so that the single punch mark falls between the two punch marks on the opposite gear (Figure 51, B).

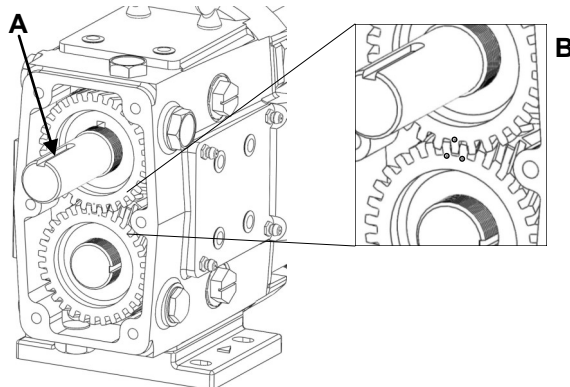

Figure 51: Installing Gears with Correct Timing

Gear Case Maintenance

9) Install the lock washers on the shaft by aligning the tab inside the lock washer with the slot in the shaft (Figure 52, A). Lubricate the threads of the lock nuts and thread them on the shafts. Using a spanner wrench, tighten them to the specified torque in Table 6. Use a wedge (wood or plastic) between the gear teeth to keep the shafts from turning while tightening the lock nuts (Figure 52, B).

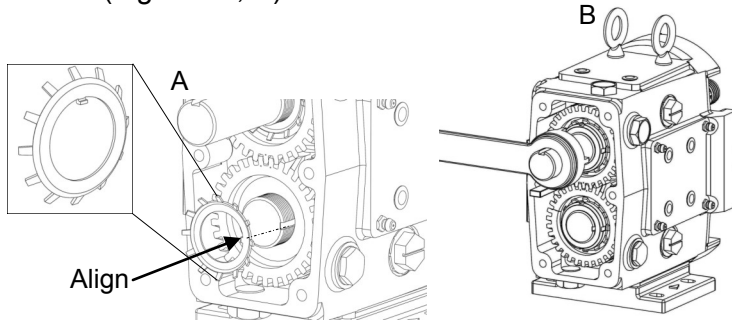

Figure 52: Installing Lock Washer and Lock Nut

Table 6: Recommended Lock Nut Torque Values

QP1 Model	Torque	
	ft-lbs	N-m
6, 15, 18	75	102
30, 34	100	136
60, 64, 130, 134	140	190
220, 224	230	312
320, 323	320	434

Secure the nut in place by bending the locking tabs on the lock washer into the lock nut slots (Figure 53).

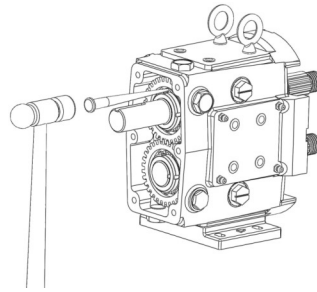

Figure 53: Bending Tabs on Lock Washer

10) Apply a light film of lubricant to the inside and outside diameters of the gear case cover oil seal. Using a press, install the oil seal into the back cover so that it is flush with the outside of the back cover and the spring is facing the gears. Apply a silicone sealant to the edges on the back of the gear case making sure there are no gaps. Slide the back cover onto the gear case, making sure that the shaft is centered on the oil seal, and secure it with the retaining bolts (Figure 54). It is important not to cut the oil seal on the shaft keyway; tape may be used to cover any sharp edges on the shaft. Install the oil plugs and fill the gear case with the recommended amount of oil using Table 3 on page 12.

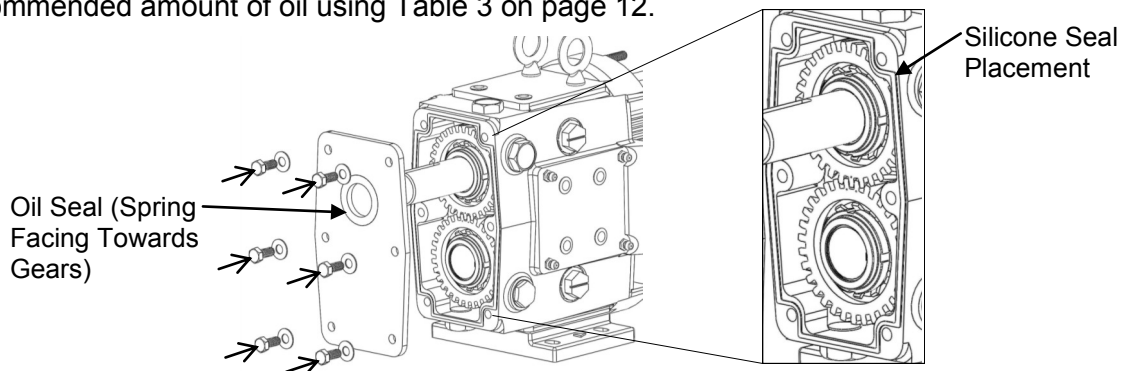

Figure 54: Installing Gear Casing Back Cover

Maintenance

Pump Assembly

1) Make sure all seal components are installed by following “Seal Maintenance” instruction provided on pages 17-20. Check to ensure all dowels are in place and that all parts including body, rotors and jam nuts are clean and free of foreign matter. Slowly slide the body over the gear case studs and shafts, ensuring the seals are kept in place and not damaged (Figure 55). Install the two hold down bolts and tighten the body against the gear case to ensure the dowels are engaged. Rotate the shafts to make sure there is no interference with the seals.

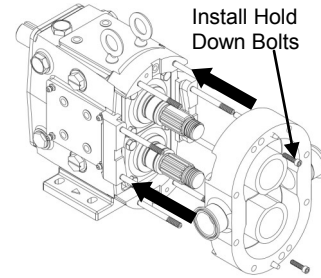

Figure 55: Installing Pump Body

2) Install a rotor onto either shaft by aligning the large spline tooth on the shaft with the large spline groove on the rotor. Secure the rotor in the body with the jam nuts. Place one nut on at a time, tightening them down using the supplied wrench and a non-metallic wedge to hold the rotor in place (Figure 56). See Table 7 for required torque values. Repeat with the second rotor.

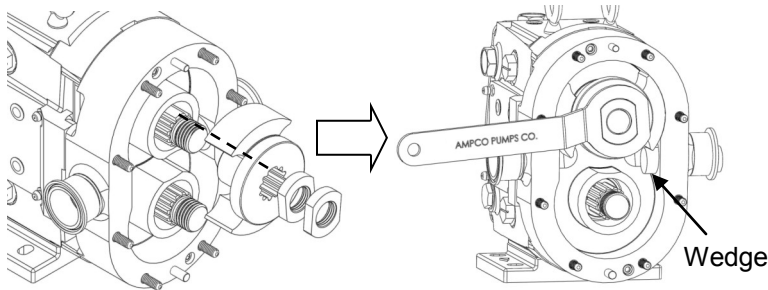

Figure 56: Installing Rotors and Tightening Jam Nuts

Table 7: Recommended Jam Nut Torque Values

QP1 Model	Torque	
	ft-lbs	N-m
6, 15, 18	30	41
30, 34	60	81
60, 64, 130, 134	75	102
220, 224	150	203
320, 323	190	258

3) Install the new cover o-ring and slide the cover over the studs making sure that the dowels in the body are aligned with the correct dowel holes in the cover (Figure 57). Visually inspect to ensure that the cover o-ring remained in place. Turn the wing nuts (clockwise) by hand and fully tighten them by striking them with a soft mallet. Tighten the wing nuts in an opposing manner as seen in Figure 58, so that the cover is evenly tightened to the body.

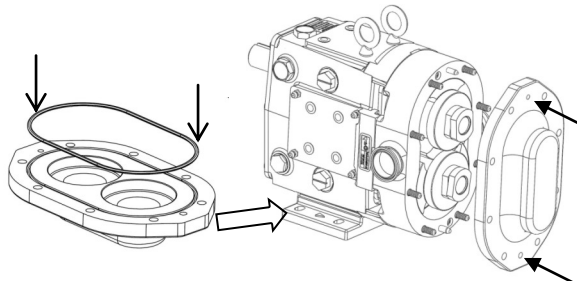

Figure 57: Installing Cover O-ring and Cover

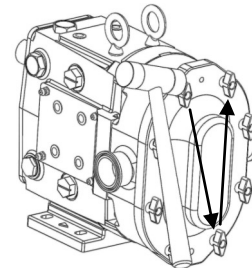

Figure 58: Tightening Cover Wing Nuts

Pump Clearances

The performance of a QP1 is based on the tight clearances between the pump body and the rotors. These clearances are critical to ensure the pump performs up to the system requirements. The clearance between the rotor and the back face of the body is referred to as the backface clearance. The backface clearances are set when the gear case is assembled (page 24) using shims placed between the gear case and the front bearing. Other clearances are shown in Figure 59 and should be in accordance to Table 8. Use shims and a depth micrometer to measure the clearances.

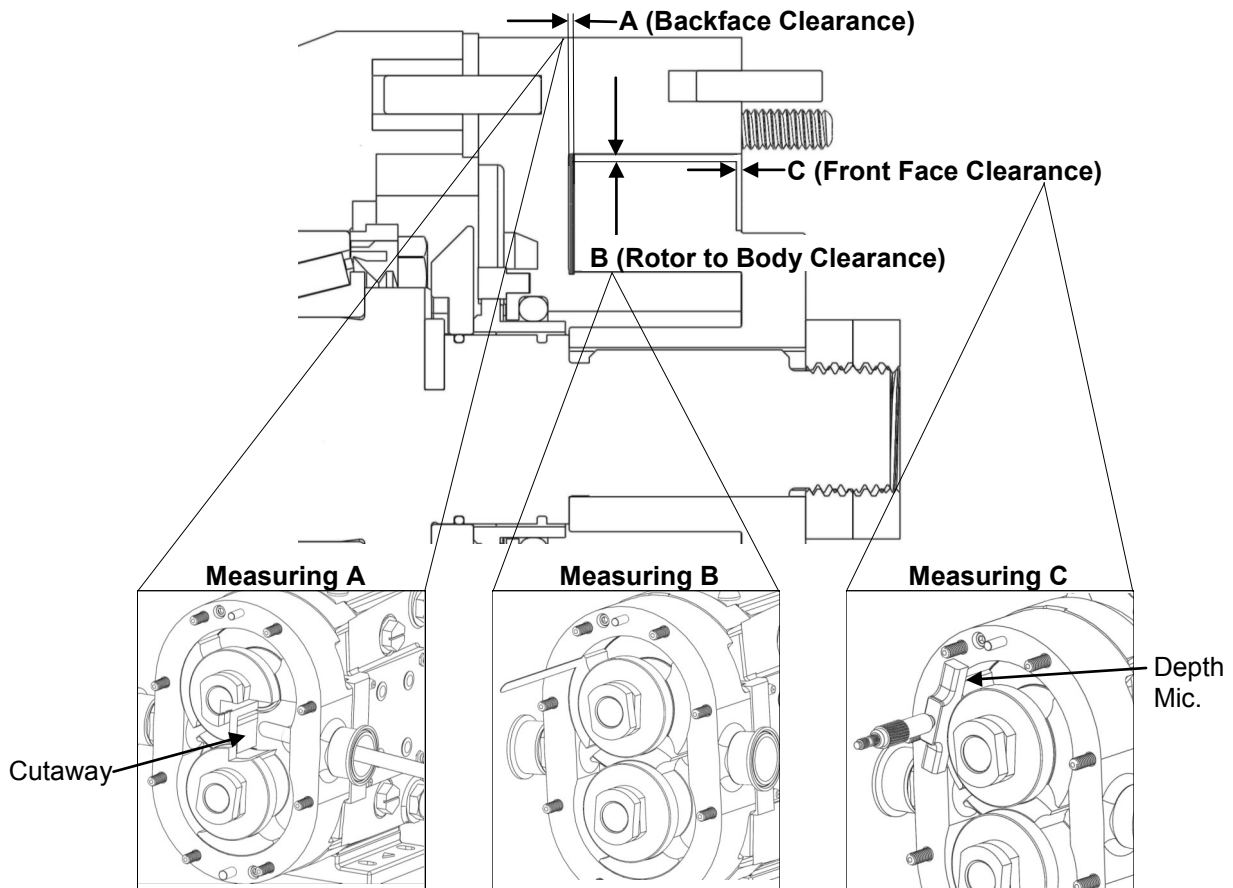

Figure 59: Critical Pump Clearances

Table 8: Critical Pump Clearance Dimensions (Standard Rotors)

Note: For non-standard rotors contact Q-Pumps	A (Backface Clearance)		B (Rotor to Body Clearance)		C (Front Face Clearance)	
	Inch	mm	Inch	mm	Inch	mm
QP1 Model						
6, 15, 18	.002	.05	.003	.076	.005	.13
30, 34	.002	.05	.003	.076	.005	.13
60, 64,	.003	.076	.005	.13	.007	.18
130, 134	.003	.076	.005	.13	.006	.15
220, 224	.005	.13	.006	.15	.007	.18
320, 323	.006	.15	.007	.18	.010	.25

Troubleshooting

The QP1 is assembled and tested at the factory and is designed to have trouble-free operation. Problems may occur over the life of the pump due to system variations, standard wear, or user error. The following table has information that may help identify and solve a problem. For additional technical assistance, please contact Q-Pumps with the pump's serial number.

Trouble	Reason	Solution
NO FLOW (rotors are not turning)	Drive motor is not running or connected	Check connection and power source to pump motor drive
	Keys (gear, drive shaft) are sheared or missing	Check or replace
	The pump's drive (gearbox, belts, transmission) is broken or slipping	Check, Replace, or adjust
	Pump shafts or gears are broken	Check and replace, if necessary
NO FLOW (rotors are turning)	Rotors are turning in the wrong direction	Check motor connections for correct hookup (see "Pump Rotation" on page 11)
	Discharge port/valve is closed or blocked	Check and open, if necessary
	Inlet port/valve is closed or blocked	Check and open, if necessary
	Pump relief valve (optional) is not set correctly, or is held open by foreign matter.	Check, clean if necessary. Check system so that unwanted debris doesn't enter pump
NO FLOW (pump is not priming)	Inlet valve closed	Open valve, if necessary
	Inlet line restricted or clogged	Clean lines and check system
	Too much air in the inlet line	Check lines for leaks, replace gaskets or pipes, if needed
	The pump's speed is too low	Increase speed of pump
	The pump's speed is too high	Check viscosity of product, and reduce speed as needed
	No product in the inlet lines (lines drain or siphon when pump is off)	Foot valves or check valves may be used. Having product in the line is necessary for the pump to prime
	Pump is air locked	Install air bleeds to the pump and lines
	Pump may be worn out	Increase the pumps speed or replace worn out rotors.
	Inlet pressures too low	Check pressure required. Change, if necessary
	Differential pressure differences not developing	Install check valves on discharge to prevent large back pressures

Troubleshooting

Trouble	Reason	Solution
Inadequate Flow	Speed is too low or too high	Check published pump curve and adjust, if necessary
	Air leaks in inlet line	Check for bad seals, bad gaskets and piping connections.
Inadequate Flow and Flow is Bypassing Pump	Open valve (inlet drain, trap valve)	Check valves and close, if needed
	Relief valve not adjusted correctly or stuck	Check relief valve and adjust, if necessary
Inadequate Flow, Pump is Noisy During Operation (slipping)	Non-standard rotors (Hot clearance, Hot Chocolate clearance, Stainless) are being used on low viscous fluids	Use appropriate rotors for product (contact Q-Pumps for additional support, if needed)
	Body and rotors are worn	Increase speeds, replace rotors, or have the pump remanufactured (Page 33)
	Pressures are too high for pump	Adjust system
Starved Pump Inlet (fluid vaporization)	Strainers, valves (inlet side), fittings, or lines are plugged or restricted	Check, and clean lines/valves. Change system, if needed
	The Inlet line is too small (inside diameter) or long, or both.	Increase inlet pipe size and/or decrease pipe length
	Too many valves or fittings	Reduce number of fittings or valves
	Valves or strainers are too small	Check and change, if necessary
	The net inlet pressure is too low	Check pump and system requirements and change system or pump, if necessary.
	Product viscosity greater than expected	Change system parameters (temperature, flow, pressure)
	Product temperature is higher than expected	Reduce speed, temperature and flow, if necessary
Excessive Power is Required (pump overheats, stalls, draws high current, fuses/breakers are tripping)	Viscosity losses higher than expected	Increase pump speed, if needed
	Pressures higher than expected	Decrease pump speeds and modify inlet line sizes
	Viscosity is higher than expected	Heat product, or change system parameters
	Viscous product sits in line during shutdown	Install a soft start on motor drive, clean lines or change system to avoid problem

Troubleshooting

Trouble	Reason	Solution
Noisy Operation (cavitation)	Product's viscosity, vapor pressure and temperature are too high	Check system setup. Change speeds and temperatures, accordingly
	The inlet pressure available is less than required	Check inlet pressure requirements and adjust accordingly (contact Q-Pumps for additional support, if needed)
Noisy Operation (air or gas in fluid)	Air leaks in the system	Check for leaks and correct, if needed
	Product emits gases	Install pressure relief valves
Noisy Operation (rotor to body contact)	Assembly without checking fluid end clearances	Check pump clearances and adjust, if necessary (page 29)
	Internal stresses in pump caused by improper piping support	Adjust system to eliminate stresses (page 8)
	Pressures are higher than what the pump is rated for	Reduce pressures
	Bearings are worn	Check for bearing movement (page 14) and replace, if necessary
Noisy Operation (rotor to rotor contact)	Gears are loose or incorrectly timed (damage to rotor may be severe)	Rebuild pump with new parts
	Keys are sheared	Inspect and rebuild if necessary
	Gears are worn	Inspect and replace gears if needed. Inspect damage to rotors and rebuild if necessary
Noisy Operation (external mechanical problems)	Gear drive, drive belts, coupling or bearings are worn or not correctly adjusted	Check and replace/adjust if needed
Short Pump Life	Product is abrasive	Check system, and possible implement a larger pump at lower speeds
	Pump speeds and pressures are higher than pump rating	Check system and change, if necessary. Reduce speeds and pressure of pump
	Improper gear case lubrication	Check and replace worn out gears and bearings; follow procedures on page 12 for proper lubrication
	Water build up in Gear case	Check that all gear case plugs are in place
	Misalignment in system (piping or pump drive)	Check and modify system to eliminate alignment issues

Reconditioning Program

PD Pump Reconditioning Program

With the purchase of each new QP pump, Q-Pumps guarantees two full reconditions. Depending on wear, the QP pumps (and equivalents) can be reconditioned up to four times. A complete recondition returns a used pump to new pump performance and appearance. Each fully reconditioned pump includes a one year warranty. The following upgrades are included when reconditioning a competitor's pump: 17-4 shafts, stainless steel bearing retainers, helical gears, and sealed clean out plugs. These upgrades are standard to Q-Pumps positive displacement new and reconditioned pumps. Recondition pricing is cost sensitive at only 67% of a new pump.

Contact your local distributor or the factory +52 (442) 218 4570 for more information.

Notes



***Q-Pumps S.A. de C.V.
Acceso "A" #103, Fracc. Ind. Jurica
Querétaro, Qro. México, 76130
Phone: +52 (442) 218 4570 or +52 (442) 103 3100
Fax: +52 (442) 218 4577
Email: sales@qpumps.com***

Additional information on the QP series and other products that Q-Pumps offers can be seen at our website: www.qpumps.com

Revision Date: May 2021
