

QP SERIES

INTERCHANGEABLE CIRCUMFERENTIAL PISTON PUMPS

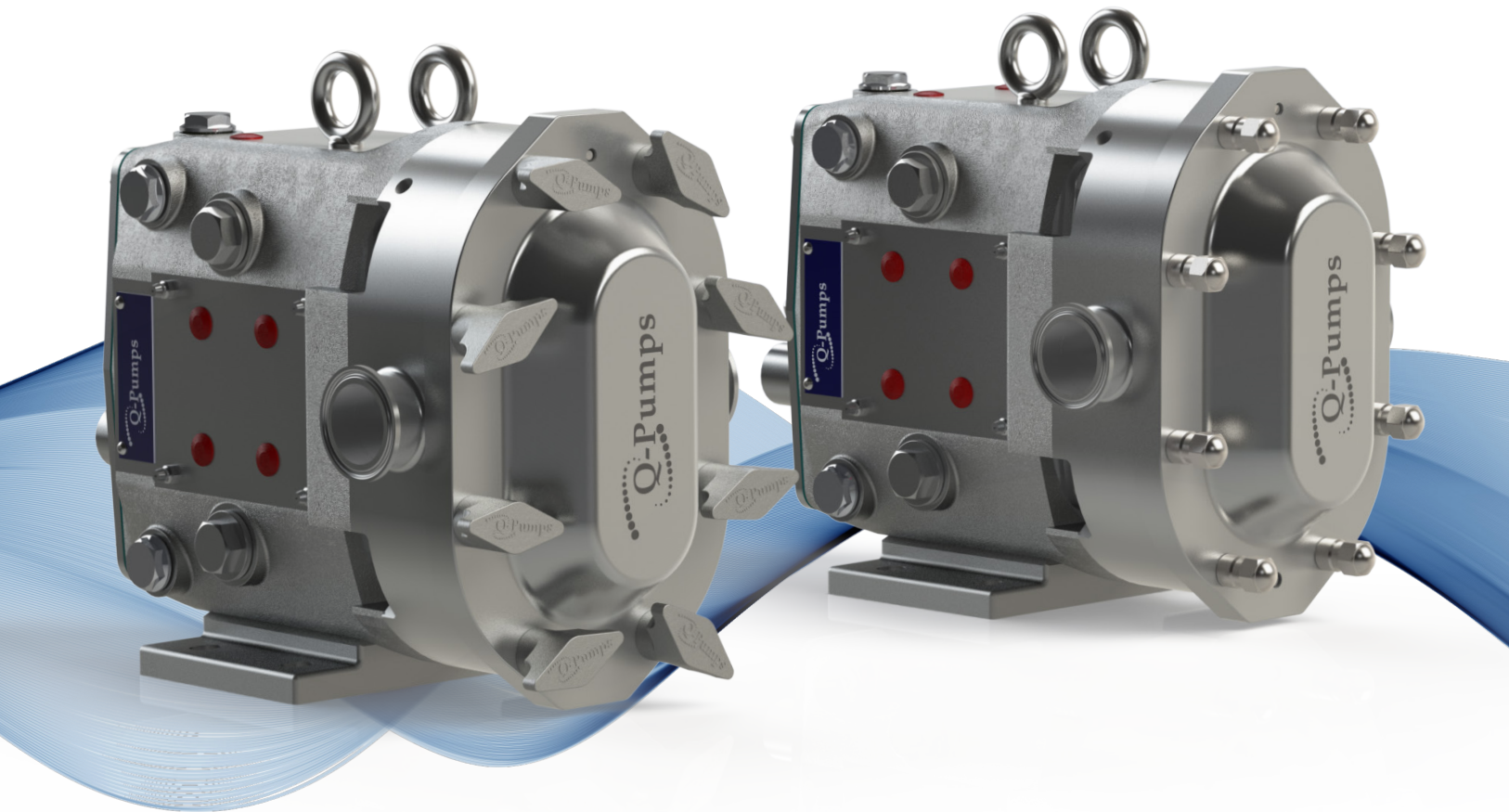

QP SERIES

QP1 and QP2 pump series are 100% dimensionally and hydraulically interchangeable with other brands in the market. Unlike the competition, Q-Pumps supplies the pump with a 304 stainless steel gearbox, without implying an increase in the final price of the equipment.



Q 452 gpm / 1711 lpm

μ up to 1000000 cP

P 500 psi / 34.5 bar
1155 ft / 352 m

T 150 °C / 302 °F

CHARACTERISTICS

- Gearbox made of stainless steel, which makes it more resistant than conventional cast-iron gearboxes.
- 304 stainless steel bearing retainers.
- Strong solid 17-4 PH stainless steel shafts.
- Alloy 88 Non-Galling Rotors.
- Helical gears.
- Flexibility for 4-Way mounting positions.
- Grease fittings and oil plugs on both sides.



ADVANTAGES:

Q-Pumps circumferential piston pumps are designed to cover all hygienic pumping applications in the food, dairy, beverage, pharmaceutical and other industries.

Due to its tight internal clearances it has a wide range of applications, from low viscosity products such as water, to highly viscous products such as glucose.

- 100% interchangeable and compatible with other series in the market
- Single alloy shafts makes them more resistant.
- Remanufacturing program: Refurbished pumps with a one-year warranty.



UNIVERSALLY INTERCHANGEABLE

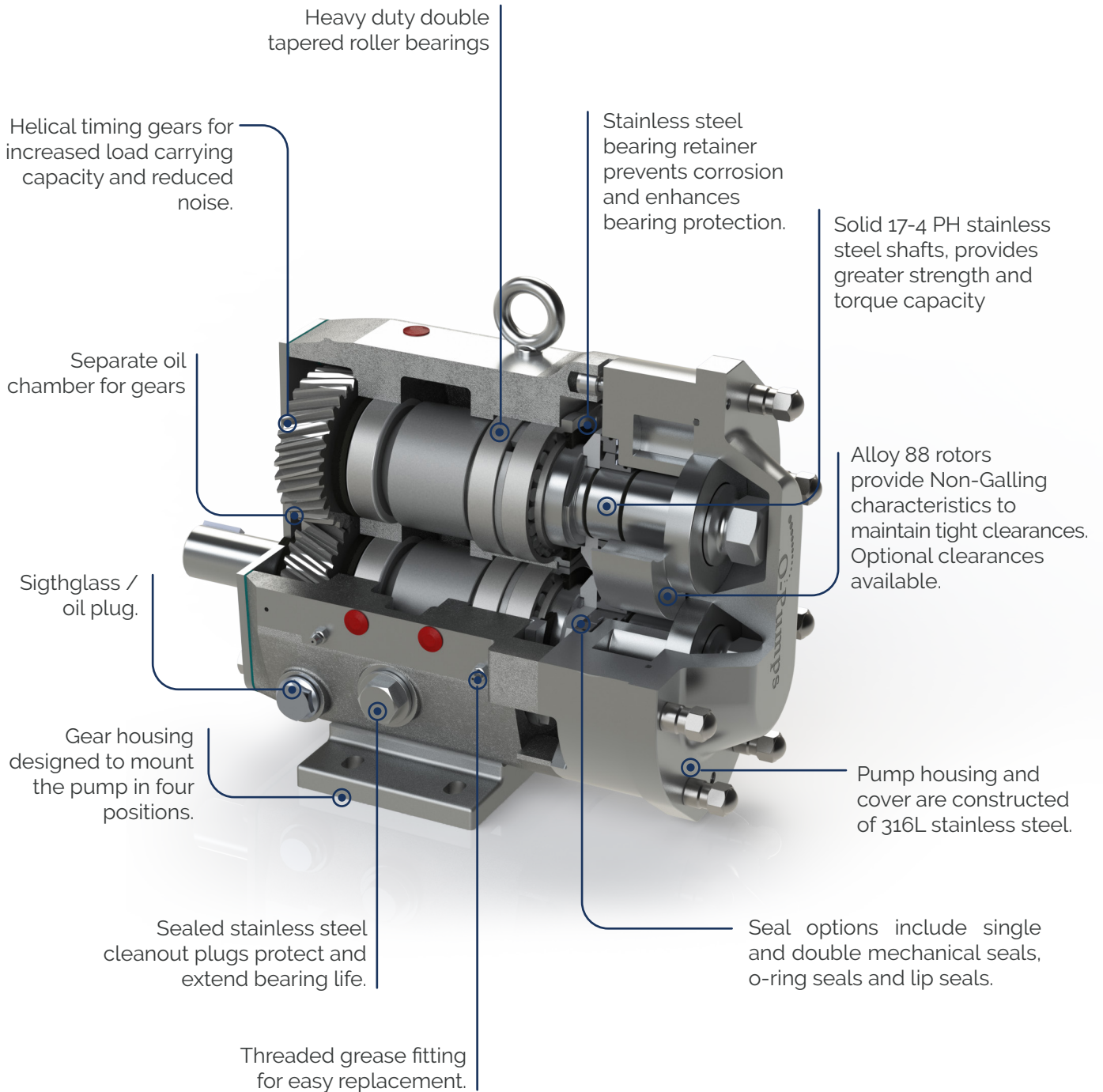

QP1 SERIES

- 3-A Certified.
- Up to 200 psi (13.8 bar) pressure capability.
- Easy disassembly for COP cleaning.
- Mechanical seals, o-ring seals and lip seals available.

QP2 SERIES

- 3-A Certified.
- Improved hygienic design.
- Up to 500 psi (34.5 bar) pressure capability.
- CIP design that improves operation costs.
- Single and double mechanical seals available.
- Larger shafts to increase pump service life.

APPLICATIONS



TECHNICAL DATA

QP1 PUMP PERFORMANCE

Model QP1	Nominal Capacity		Displacement		Maximum Differential Pressure		Standard Port Size		Optional Port Size		Maximum Speed rpm	Temperature Range	
	gpm	lpm	Gal/Rev	L/Rev	psi	bar	in	DN mm	in	DN mm		°F	°C
6	7	24.8	0.0082	0.031	200	13.8	1	25	1 ½"	40	800	-40° a 300°	-40° a 149°
15	10	37.6	0.0142	0.054	200	13.8	1 ½"	40	-	-	700		
18	17	65.9	0.029	0.110	200	13.8	1 ½"	40	2"	50	600		
30	36	136.6	0.060	0.227	200	13.8	1 ½"	40	2"	50	600		
40	46	172.6	0.076	0.228	150	10.3	2"	50	2 ½"	65	600		
60	92	347.5	0.153	0.579	200	13.8	2 ½"	65	3"	80	600		
130	152	576.8	0.254	0.961	200	13.8	3"	80	-	-	600		
220	313	1185.5	0.522	1.976	200	13.8	4"	100	-	-	600		
320	452	1712.3	0.754	2.854	200	13.8	6"	150	-	-	600		

Rectangular Inlet Option													
	Nominal Capacity		Displacement		Maximum Differential Pressure		Rectangular Inlet (WxL)		Discharge Port Size		Maximum Speed rpm	Temperature Range	
	gpm	lpm	Gal/Rev	L/Rev	psi	bar	in	mm	in	DN mm		°F	°C
34	24	90.8	0.060	0.227	200	13.8	1.75 x 6.75	44 x 171	2"	50	400	-40° a 300°	-40° a 149°
64	61	231.6	0.153	0.579	200	13.8	2.24 x 8.82	57 x 224	2 ½" (3")	65 (80)	400		
134	102	384.6	0.254	0.961	200	13.8	2.97 x 9.25	75 x 235	3"	80	400		
224	208	788.8	0.521	1.972	200	13.8	3.78 x 11	98 x 279	4"	100	400		
324	301	1139.2	0.754	2.854	200	13.8	5.00 x 17.38	127 x 441	6"	150	400		

QP2 PUMP PERFORMANCE

Model QP2	Nominal Capacity		Displacement		Maximum Differential Pressure		Standard Port Size		Optional Port Size		Maximum Speed rpm	Temperature Range	
	gpm	lpm	Gal/Rev	L/Rev	psi	bar	in	DN mm	in	DN mm		°F	°C
6	8	1.0	0.0082	0.031	300	20.7	1	25	1 ½"	40	1000	-40° a 300°	-40° a 149°
15	11	43.0	0.0142	0.054	250	17.2	1 ½"	40	-	-	800		
18	20	76.8	0.029	0.110	200	13.8	1 ½"	40	2"	50	700		
30	36	136.3	0.060	0.227	250	17.2	1 ½"	40	2"	50	600		
40	46	172.6	0.076	0.288	150	10.3	2"	50	2 ½"	65	600		
45	59	222.6	0.098	0.371	450	31.0	2"	50	-	-	600		
60	92	347.5	0.153	0.579	300	20.7	2 ½"	65	3"	80	600		
130	152	576.8	0.254	0.961	200	13.8	3"	80	-	-	600		
180	228	863.0	0.380	1.438	450	31.0	3"	80	-	-	600		
210	301	1140.0	0.502	1.900	500	34.5	4"	100	-	-	600		
220	313	1185.5	0.522	1.976	300	20.7	4"	100	-	-	600		
320	452	1712.3	0.754	2.854	300	20.7	6"	150	-	-	600		

Rectangular Inlet Option													
	Nominal Capacity		Displacement		Maximum Differential Pressure		Rectangular Inlet (WxL)		Discharge Port Size		Maximum Speed rpm	Temperature Range	
	gpm	lpm	Gal/Rev	L/Rev	psi	bar	in	mm	in	DN mm		°F	°C
34	24.0	90.8	0.060	0.227	250	17.2	1.81 x 6.84	44 x 174	2"	50	400	-40° a 300°	-40° a 149°
64	61.2	231.6	0.153	0.579	300	20.7	2.44 x 9.0	62 x 229	2 ½" (3")	65 (80)	400		
134	101.6	384.6	0.254	0.961	200	13.8	3.19 x 9.38	81 x 238	3"	80	400		
224	208	788.8	0.521	1.972	300	20.7	4.06 x 11.25	103 x 2786	4"	100	400		
324	301	1517.7	0.752	2.847	300	20.7	4.25 x 12.7	108 x 322.5	6"	150	400		

QP1 DIMENSIONS

Model QP1		A	B	C	D	E	F	G	H	J	K
6	IN	4.75	1.95	3.75	12.04	5.50	1.94	2.31	.41, SLOT	2.93	9.61
	MM	.21	50	95	306	140	49	59	10, SLOT	74	244
15	IN	4.75	1.95	3.75	12.04	5.50	1.94	2.31	.41, SLOT	2.93	9.61
	MM	121	50	95	306	140	49	59	10, SLOT	74	244
18	IN	4.75	2.18	3.75	12.46	5.50	1.94	2.31	.41, SLOT	2.93	9.84
	MM	121	55	95	316	140	49	59	10, SLOT	74	250
30	IN	6.25	2.78	4.25	14.58	6.86	2.31	2.56	.41, SLOT	3.56	11.61
	MM	159	71	108	370	174	59	65	10, SLOT	90	295
40	IN	6.25	2.94	4.25	14.96	6.86	2.31	2.56	.41, SLOT	3.56	11.99
	MM	159	75	108	380	174	59	65	10, SLOT	90	305
60	IN	8.25	4.14	5.87	18.91	9.56	3.50	4.12	0.53	5.06	15.14
	MM	210	105	149	480	243	89	105	13	129	385
130	IN	8.25	4.78	5.87	19.85	9.56	3.50	4.12	0.53	5.06	15.77
	MM	210	121	149	504	243	89	105	13	129	401
220	IN	8.50	3.69	9.00	23.37	12.38	3.75	7.25	.53, SLOT	6.38	18.49
	MM	216	94	229	594	314	95	184	13 SLOT	162	470
320	IN	12.00	4.12	11.63	30.17	13.88	5.25	8.00	.66, SLOT	6.88	21.92
	MM	305	105	295	766	353	133	203	17 SLOT	175	557
323	IN	12.00	4.12	11.63	30.17	13.88	5.25	8.00	.66, SLOT	6.88	21.92
	MM	305	105	295	766	353	133	203	17 SLOT	175	557

QP2 DIMENSIONS

Model QP2 / OP3		A	B	C	D	E	F	G	H	J	K
6	IN	4.75	1.95	3.75	11.80	5.50	1.94	2.31	.41, SLOT	2.93	9.61
	MM	1.21	50	95	300	140	49	59	10, SLOT	74	244
15	IN	4.75	1.95	3.75	11.80	5.50	1.94	2.31	.41, SLOT	2.93	9.61
	MM	121	50	95	300	140	49	59	10, SLOT	74	244
18	IN	4.75	2.18	3.75	12.49	5.50	1.94	2.31	.41, SLOT	2.93	9.84
	MM	121	55	95	317	140	49	59	10, SLOT	74	250
30	IN	6.25	2.78	4.25	14.58	6.86	2.31	2.56	.41, SLOT	3.56	11.61
	MM	159	71	108	370	174	59	65	10, SLOT	90	295
40	IN	6.25	2.94	4.25	14.87	6.86	2.31	2.56	.41, SLOT	3.56	11.99
	MM	159	75	108	380	174	59	65	10, SLOT	90	305
45	IN	8.25	3.86	5.87	18.56	9.56	3.50	4.12	0.53	5.06	14.86
	MM	210	98	149	471	243	89	105	13	129	377
60	IN	8.25	4.14	5.87	19.32	9.56	3.50	4.12	0.53	5.06	15.14
	MM	210	105	149	491	243	89	105	13	129	385
130	IN	8.25	4.78	5.87	20.33	9.56	3.50	4.12	0.53	5.06	15.77
	MM	210	121	149	516	243	89	105	13	129	401
180	IN	8.50	3.45	9.00	23.53	12.38	3.75	7.25	.53, SLOT	6.38	18.25
	MM	216	88	229	598	314	95	184	13 SLOT	162	464
220	IN	8.50	3.69	9.00	24.27	12.38	3.75	7.25	.53, SLOT	6.38	18.49
	MM	216	94	229	616	314	95	184	13 SLOT	162	470
210	IN	12.00	3.45	11.63	27.08	13.88	5.25	8.00	.66, SLOT	6.88	21.24
	MM	305	88	295	688	353	133	203	17 SLOT	175	539
320	IN	12.00	3.84	11.63	27.66	13.88	5.25	8.00	.66, SLOT	6.88	21.92
	MM	305	98	295	703	353	133	203	17 SLOT	175	557

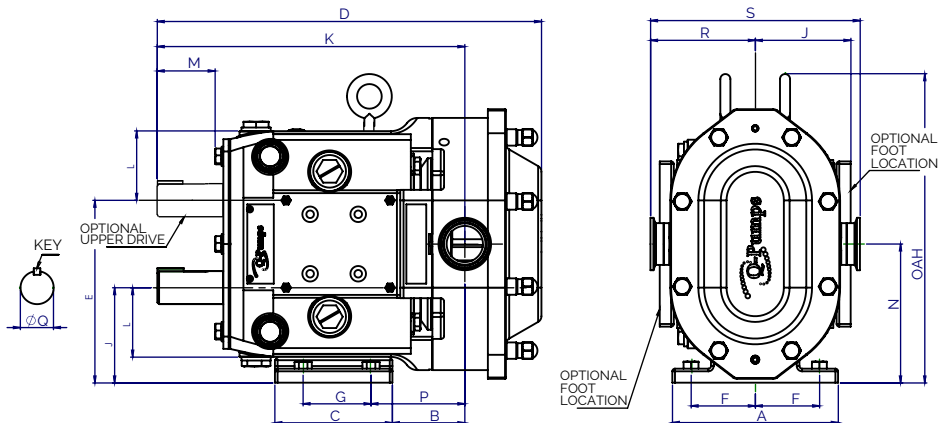

QP1 DIMENSIONS

L	M	N	Port Size	P	Q	Key	R	S	OAH	Weight	
2.12	2.00	4.21	1"	2.79	0.875	0.1875	3.49	6.97	8.30	LB	60
54	51	107	25	71	22.2	4.76	89	177	211	KG	27
2.12	2.00	4.21	1½"	2.79	0.875	0.1875	3.49	6.97	8.30	LB	60
54	51	107	38	71	22.2	4.76	89	177	211	KG	27
2.12	2.00	4.21	1½"	3.02	0.875	0.1875	3.55	7.09	8.30	LB	64
54	51	107	38	77	22.2	4.76	90	180	211	KG	29
2.62	2.32	5.21	1½"	3.84	1.25	0.250	4.25	8.50	10.29	LB	130
67	59	132	38	98	31.8	6.35	108	216	261	KG	59
2.62	2.32	5.21	2"	4.00	1.25	0.250	4.31	8.62	10.29	LB	140
67	59	132	51	102	31.8	6.35	109	219	261	KG	64
3.50	2.25	7.31	2½"	5.01	1.625	0.375	5.37	10.75	15.31	LB	285
89	57	186	64	127	41.3	9.53	136	273	389	KG	129
3.50	2.25	7.31	3"	5.65	1.625	0.375	5.37	10.75	15.31	LB	305
89	57	186	76	144	41.3	9.53	136	273	389	KG	138
4.50	2.75	9.38	4"	4.44	2.00	0.500	6.63	13.25	19.13	LB	565
114	70	238	102	113	50.8	12.70	168	337	486	KG	256
5.06	4.06	10.38	6" 150# FLG	5.37	2.375	0.625	8.00	16.00	22.38	LB	900
129	103	264		136	60.3	15.88	203	406	568	KG	408
5.06	4.06	10.38	6" 150# FLG	5.37	2.375	0.625	8.00	16.00	22.38	LB	900
129	103	264		163	60.3	15.88	203	406	568	KG	408

QP2 DIMENSIONS

L	M	N	Port Size	P	Q	Key	R	S	OAH	Weight	
2.12	2.00	4.21	1"	2.79	0.875	0.1875	3.49	6.97	8.30	LB	56
54	51	107	25	71	22.2	4.76	89	177	211	KG	25
2.12	2.00	4.21	1½"	2.79	0.875	0.1875	3.49	6.97	8.30	LB	60
54	51	107	38	71	22.2	4.76	89	177	211	KG	27
2.12	2.00	4.21	1½"	3.02	0.875	0.1875	3.49	6.97	8.30	LB	65
54	51	107	38	77	22.2	4.76	89	177	211	KG	30
2.62	2.32	5.21	1½"	3.84	1.25	0.250	4.25	8.50	10.29	LB	130
67	59	132	38	98	31.8	6.35	108	216	261	KG	59
2.62	2.32	5.21	2"	4.00	1.25	0.250	4.31	8.62	10.29	LB	140
67	59	132	51	102	31.8	6.35	109	219	261	KG	64
3.50	2.25	7.31	2"	4.73	1.625	0.375	5.37	10.75	15.31	LB	265
89	57	186	51	120	41.3	9.53	136	273	389	KG	120
3.50	2.25	7.31	2½"	5.01	1.625	0.375	5.37	10.75	15.31	LB	285
89	57	186	64	127	41.3	9.53	136	273	389	KG	129
3.50	2.25	7.31	3"	5.65	1.625	0.375	5.37	10.75	15.31	LB	305
89	57	186	76	144	41.3	9.53	136	273	389	KG	138
4.50	2.75	9.38	3"	4.20	2.00	0.500	6.53	13.06	19.13	LB	520
114	70	238	76	107	50.8	12.70	166	332	486	KG	236
4.50	2.75	9.38	4"	4.44	2.00	0.500	6.63	13.25	19.13	LB	590
114	70	238	102	113	50.8	12.70	168	337	486	KG	268
5.06	4.06	10.38	4"	4.70	2.38	0.625	7.38	14.75	22.38	LB	802
129	103	264	102	119	60.5	15.88	187	375	568	KG	364
5.06	4.06	10.38	6" 150# FLG	5.09	2.38	0.625	8.00	16.00	22.38	LB	850
129	103	264		129	60.5	15.88	203	406	568	KG	386

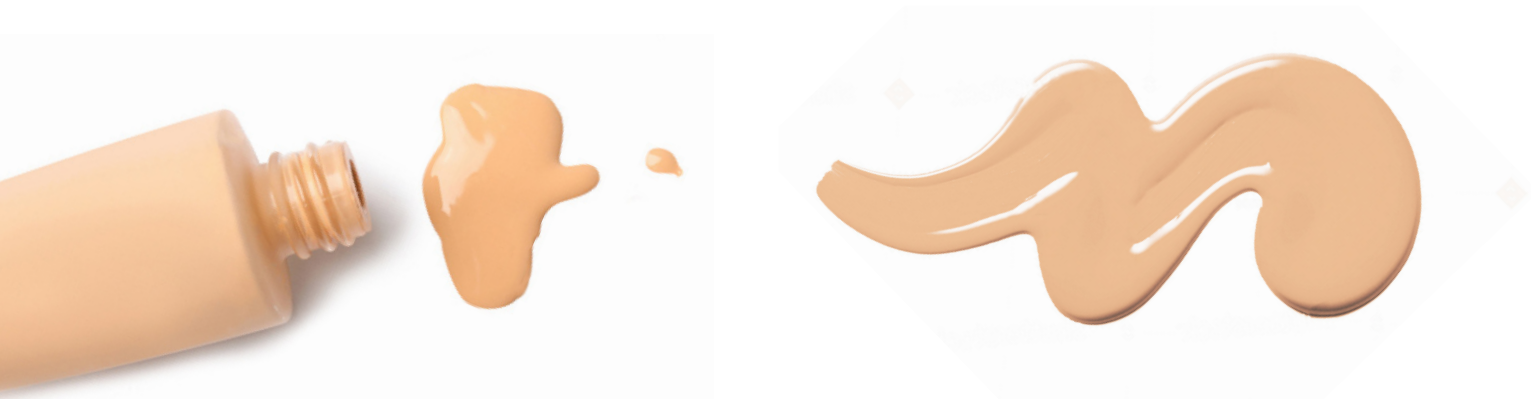

QP SERIES

INTERCHANGEABLE CIRCUMFERENTIAL PISTON PUMPS

REMANUFACTURING PROGRAM

The Remanufacturing Program provides a remanufactured pump with completely new shafts, bearings, seals, helical style gears and Alloy 88 rotors , allowing customers to purchase a new pump with a significant saving.

MODELS

Cross Reference	
Q-Pumps	Other Brands
QP1	Universal1 / TRA10 / ZP1
QP2	Universal2 / TRA20 / ZP2

Distributed by:

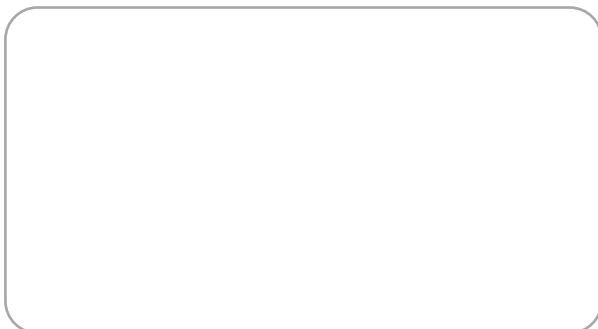

For more information visit: en.q-pumps.com
or call us +1 (614) 966 81 50
+1 (281) 728 62 52