

# Q-Pumps

THE BEST SOLUTION FOR YOUR  
**SANITARY PROCESSES**

## Z SERIES

Centrifugal Pumps

Installation and Maintenance Manual



## Table of Contents

---

<b>Introduction</b> .....	<b>3</b>
Introduction .....	3
General Information .....	3
Shipping Damage or Loss.....	3
<b>Receiving/Safety</b> .....	<b>4</b>
Pump Receiving.....	4
Safety.....	4
<b>Pump Information</b> .....	<b>5</b>
Instructions.....	5
Location .....	5
Installation.....	5
<b>Maintenance</b> .....	<b>5</b>
<b>Service</b> .....	<b>6</b>
<b>Single Mechanical Seal</b> .....	<b>9</b>
<b>Applications</b> .....	<b>11</b>
<b>Troubleshooting</b> .....	<b>12</b>
<b>Q-Pumps Terms and Conditions</b> .....	<b>13</b>
<b>Return Policy</b> .....	<b>16</b>

## Introduction

---

### Introduction

To ensure the best results and service, please read and fully understand this manual prior to putting this pump into service. For any questions regarding operation, maintenance, or installation, please contact your Distributor or Q-Pumps. Q-Pumps contact information is as followed:

Q-Pumps S.A. de C.V.  
Acceso "A" #103, Fracc. Ind. Jurica  
Querétaro, Qro. México, 76130  
Phone: +52 (442) 218 4570 or +52 (442) 103 3100  
Fax: +52 (442) 218 4577  
Email: sales@qpumps.com

### General Information

Each Z pump is fully assembled, lubricated, and tested at the factory and shipped ready for use. Standard maintenance practices are outlined in this manual. For more information, please refer to the Maintenance section. Following these guidelines will provide long-lasting, trouble-free service when the pump(s) is incorporated in a properly designed system.

### Shipping Damage or Loss

Upon receiving equipment that is damaged or if your shipment is lost in transit, immediately file a claim with the carrier. At time of pick-up, the carrier signed the bill of lading, acknowledging that they have received the product from Q-Pumps in good condition.

## Receiving/Safety

---

### Pump Receiving

Q-Pumps covers the pump inlet and discharge ports prior to shipping, ensuring that foreign matter does not enter the pump during shipment. If the protective covers are missing upon arrival, remove the pump cover and inspect to ensure it is free from contaminate before turning the shafts. Please make note of the pump serial number; this will assist in the process of ordering replacement parts and/or a warranty claim. For more information regarding shipment damage or warranty, please refer to Terms and Conditions.

### Safety

**IMPORTANT:** Read and understand this manual BEFORE installation, operation or maintenance of the pump. Improper installation, operation, or maintenance may result in severe injury or death. Equipment damage caused by user neglect will invalidate the pump warranty.

There are safety symbols used throughout this manual identifying safety concerns.



***WARNING:*** Hazards or unsafe practices that COULD result in severe personal injury or death, and how to avoid them.

***CAUTION:*** Hazards or unsafe practices that COULD result in minor personal injury or damage to product or property.

## Pump Information

---

### Instructions

The care required of this pump, while nominal, is very important. We recommend a careful review of the installation and maintenance covered in this manual to ensure extended trouble-free service.

### Location

The motors used on Q-Pumps units have been selected as the best for the anticipated environment. For greatest service life, mount the pump and motor where the environment is relatively clean, dry, and non-corrosive. Standard totally enclosed motors may be installed where dirt, moisture, and mild corrosion are present or in outdoor locations. Specialty motors may be required for moist, corrosive, or explosive environments. Motor drain plugs (if not equipped with automatic drains) must be removed periodically to drain accumulated condensation. Pump units should be located where daily visual inspection is possible and no surrounding structure interferes with ventilating air over or through the motor.

### Installation

Installation of Q-Pumps should be made as close to the supply of liquid as possible, with short and direct suction piping. Avoid high points in the piping where air pockets can form. The suction and discharge piping should be simple with the connections properly aligned to prevent any strain from being placed on the pump casing. Provisions should be made for pipe expansion and contraction in services handling hot or cold liquids. Base-mounted pedestal pumps must be realigned AFTER installation and piping is completed.

### Maintenance

Daily observation of Q-Pumps while in operation is the ounce of prevention needed to extend the service life. Mechanical seals are selected for maximum life with due consideration to the economy of the installation. The seal is the only expendable item. Other pump parts are designed for indefinite life expectancy, except as they may be corroded and/or eroded by aggressive products or by misapplication such as under sizing, oversizing, cavitation, etc. Bearings on some pedestal pumps and some motors are pre-lubricated and require no additional lubrication. The schedule for re-greasing other types of bearings will vary, depending on size, speed, duty, and environment. For guidance, a steady running, indoor installation in a relatively clean atmosphere at 4°C (104°F) ambient should not require grease for two years. Care should also be taken not to over grease motors. Pumps handling corrosive or otherwise aggressive solutions should be flushed with clean water after each use because stagnant conditions are usually most corrosive. In seawater, Q-Pumps Alloy pumps provide cathode protection for stainless steel parts. To prevent crevice corrosion and pitting, drain and then flush the pump with fresh water when inactive for periods greater than one week.

Q-Pumps “Z” Series pumps fitted with standard mechanical seals have all-metal seal parts of 316 stainless steel, carbon rotating face, ceramic stationary seat, and Buna-N elastomers. Other seal types are supplied when specified. Optional materials such as Viton, EPDM, or Teflon elastomers, Tungsten Carbide, Silicon Carbide, or Ni-Resist faces can be supplied when requested.

## Service

---

The mechanical seal should be replaced at the first sign of leakage where the shaft enters the pump. Leakage may cause motor bearing damage. Also, since the primary seal surfaces are lapped to precise flatness, the seal should be replaced whenever the pump is dismantled to the point of separating the seal faces. Always keep a replacement seal kit on hand. It includes a complete seal along with the gasket and o-ring required to rebuild the pump.

There may be other pump assemblies; parts and seal arrangements not shown or otherwise described in this pamphlet, which require the same philosophy of seal positioning. It is suggested that highlights of these instructions be applied while paying close attention to parts arrangement during dismantling.

### **Mechanical Seals (Self-Locating)**

The instructions on the following pages are specifically for bellows type mechanical seals. Being self-locating, the rotating parts need only to be approximately positioned on the shaft sleeve so that contact occurs between the rotating and stationary seal parts before the sleeve butts against the locating shaft shoulder. This sequence of contact will cause the oil-lubricated rotating seal to slide along the sleeve to the correct location. The oil-softened film will then set up, bonding the bellows to the shaft sleeve to maintain position and transmit torque.

### **Mechanical Seals (not Self-Locating) Type-9**

Mechanical seals which are not self-locating require seal manufacturer's instructions as to the initial spring compression, drive collar location, etc. Following those instructions, the assembler may best determine and mark such locations on the shaft or sleeve by first assembling the pump without the seal. The gland location or end stuffing box may then be scribed onto the shaft or sleeve as a reference point for locating seal's rotating parts in relation to stationary parts.

## Service

### **Dismantle and Replace Parts as Follows:**

Before attempting any service on the pump or motor, disconnect or lock out electrical power to the pump motor. If the pump and motor are to be removed as a unit, note the wiring configuration. Use colored or numbered tape to mark the wire connections of the motor and power source, to retain correct direction of rotation when reconnecting. Incorrect rotation may cause catastrophic failure.

1. Remove casing by unbolting the casing bolts. There is a choice of (a) first removing the inlet and discharge piping, or (b) sliding the motor and remaining pump parts back and free of the casing without disturbing the piping.
2. Remove the impeller screw. Ease the impeller off the shaft. Pinch bars between the impeller and cover may be required. Remove the impeller key.
3. The shaft sleeve and rotating parts of the seal are removed by drawing the sleeve off the shaft (Initial use of anti-seize lubricant should permit hand removal). A puller, if necessary, should be the type that grips the O.D. The cover may now be removed from the adapter or pedestal. This is a piloting fit, pry if tight.

## Service

---

**The fluid end is now completely dismantled; additional procedures are dictated by purpose for which unit was disassembled.**

These instructions are limited to fluid ends only. See other drawings and literature applicable to motors, pedestals, frames, shafts, bearings, etc. if additional repairs are required.

**The mechanical seal is the only expendable pump part. It is suggested that the complete mechanical seal, both stationary and rotating members, be replaced whenever dripping or leakage occurs at the shaft, or whenever parts are removed to the point of separating the primary sealing surfaces. Replace shaft sleeve if worn or damaged.**

4. The seal's flexible bellows may stick tightly to the sleeve. Bathe in oil to soften the adhesive, or cut away with a knife. Remove the o-ring from the shaft I.D. (ZCH2 models only).

5. Press the seal's stationary seat with cup or o-ring out of the cover.

6. Thoroughly clean sleeve, seat cavity, and shaft with solvent and dry with a clean cloth.

**Loss of capacity and/or head due to excessive running clearance (1/16" or more per side) between impeller and casing ring may be restored by replacing wear ring (Z Series pump only).**

7. The wear ring is a press fit in the casing, To remove the ring cut through two sides, releasing the pressure of the press fit. This may be accomplished by drilling a hole through longitudinal dimension of the ring, then cracking the remaining ring wall. Drill size "a" is the appropriate size.

8. When inserting a new ring, be sure the matching surfaces are clean and free of burrs. Press the new ring in, keeping it perfectly straight. If no press is available ring may be driven in with a hammer and wood or suitable fiber block.

Replacement of other parts is accomplished by substituting during normal assembly as follows:

### **Mechanical Seal Replacement and Reassembly**

The rotating portion of the mechanical seal is positioned by sliding the sleeve into position as the impeller screw draws the impeller into place. Oiling the O.D. of the sleeve and the I.D. of the seal facilitates this by softening an adhesive film on the seal (Use soap, glycerin, etc. if oil is not permitted i.e. EPDM). Do not use grease, as this would prevent the adhesive film from resetting. Final adherence to the sleeve is essential for shaft, sleeve, and seal to rotate as a unit.

#### **Proceed as Follows:**

1. Lightly oil bore and finger press stationary seat with gasket or o-ring into this cavity. Seat (usually ceramic) is fragile. Do not abuse.

2. Oil and hand fit (no tools) rotating portion of mechanical seal onto sleeve. Check direction, carbon should face small end of the sleeve. Complete assembly without delay after seal is placed on the sleeve.

## Service

---

3. Slip cover and seat over the shaft into its locating bore positioning the internal bypass hole between 1 and 2 o'clock for top discharge. Avoid bumping the seat into the shaft.

4. Insert sleeve I.D. o-ring (ZCH2 models only). Lubricate I.D. of sleeve and shaft O.D. with an anti-seize lubricant. Slide sleeve with seal parts onto the shaft, the carbon washer should contact its mating stationary seat before the sleeve engages the shaft shoulder. Continue to push the sleeve through the seal parts until the sleeve nears its final position.

Engage the spring with the rotating seal assembly by passing it over the large end of the sleeve (discard seal spring retainer).

5. Place the o-ring in the end of the sleeve. Align the keyways and insert the key. Place the gasket or o-ring in the impeller depending on style and slide the impeller onto the shaft over the key. Use blue Loctite #242 on the impeller screw threads and hand tighten the impeller screw.

6. Tighten the impeller screw with a 6 point socket until the sleeve is against the shaft shoulder and all rotating parts are secure. A screwdriver or equivalent placed into the impeller O.D. will steady the rotating assembly for tightening. Check the freedom of parts by hand rotating the impeller.

7. Install a new casing gasket on the shoulder of the cover. Place the casing in position and secure with the eight cap screws. Tighten the cap screws uniformly. Rotate the impeller by hand again to check for rubbing.

**One way to damage a new seal is to run it dry. Be sure pump is in place and primed before operating.**

8. Place the pump back into service and inspect for proper rotation and leaks.



# Single Mechanical Seal T-21

## ZC2/ZCH2 PUMPS

1 1/2x1 1/4, 2x1 1/2, 2 1/2x2, 3x2 1/2, 4x3; KC2 1 1/2x1 1/4, 2x1 1/2

Q-PUMPS S.A DE C.V.

### PARTS BREAKDOWN

DETAIL NO.	REQ. NO.	PART NAME
22 <sup>1,3</sup>	1	WEAR RING (COVER)
21 <sup>2</sup>	1	O-RING (SHAFT/SLEEVE)
20 <sup>1</sup>	2	PIPE PLUG (OPTIONAL)
19	1	MOTOR
18	8	CAP SCREW (CASING/ADAPTER)
17	4	CAP SCREW (MOTOR/ADAPTER)
16 <sup>1</sup>	2	DRIVE SCREW
15 <sup>1</sup>	1	NAME PLATE
14	1	MECHANICAL SEAL
13	1	IMPELLER KEY
12	1	SPLASH PLATE
11	1	O-RING (SLEEVE/IMPELLER)
10	1	GASKET or O-RING (IMPELLER SCREW)
9	1	GASKET (CASING/COVER)
8	1	SLINGER
7	1	IMPELLER SCREW
6	1	SHAFT SLEEVE
5	1	WEAR RING (SUCTION)
4	1	ADAPTER
3	1	IMPELLER
2	1	COVER
1	1	CASING

<sup>1</sup>NOT SHOWN

<sup>2</sup>ZCH2 ONLY

<sup>3</sup>ZC2/ZCH2 4x3 ONLY

NOTE: Please be sure to always include pump type, size, and serial number with any reference to above numbers and names.

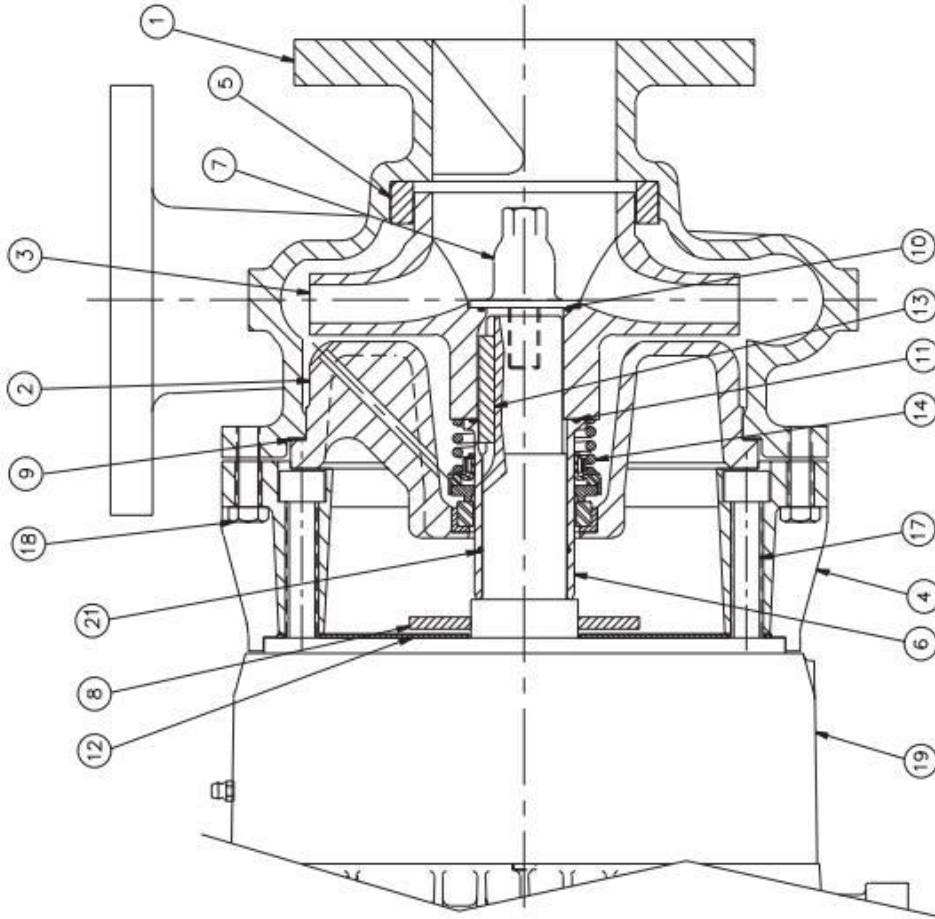

# Single Mechanical Seal T-21

## ZC2/ZCH2 PUMPS

1 1/2x1 1/2, 2x2, 3x2, 4x3L, 4x3C, 5x4, 5x4P, 6x6

Q-PUMPS S.A DE C.V.

### PARTS BREAKDOWN

DETAIL REQ. NO.	NO.	PART NAME
	24	1 STUFFING BOX GASKET
	23	1 STUFFING BOX
	22 <sup>3</sup>	1 WEAR RING (COVER)
	21 <sup>2</sup>	1 O-RING (SHAFT/SLEEVE)
	20 <sup>1</sup>	2 PIPE PLUG (OPTIONAL)
	19	1 MOTOR
	18B	4 CAP SCREW (COVER/STUFFING BOX)
	18A	X <sup>4</sup> CAP SCREW (CASING/COVER)
	18	8 CAP SCREW (COVER/ADAPTER)
	17	4 CAP SCREW (MOTOR/ADAPTER)
	16 <sup>1</sup>	2 DRIVE SCREW
	15 <sup>1</sup>	1 NAME PLATE
	14	1 MECHANICAL SEAL
	13	1 IMPELLER KEY
	12	1 SPLASH PLATE
	11	1 GASKET (SLEEVE/IMPELLER)
	10	1 GASKET or O-RING (IMPELLER SCREW)
	9	1 GASKET (CASING/COVER)
	8	1 SLINGER
	7	1 IMPELLER SCREW
	6	1 SHAFT SLEEVE
	5 <sup>5</sup>	1 WEAR RING (SUCTION)
	4	1 ADAPTER
	3	1 IMPELLER
	2	1 COVER
	1	1 CASING

<sup>1</sup>NOT SHOWN

<sup>2</sup>ZCH2 ONLY

<sup>3</sup>NOT ON 1 1/2x1 1/2, 6x6

<sup>4</sup>8-1 1/2x1 1/2, 2x2, 5x4P, 6x6 12-3x2, 4x3L, 4x3C, 5x4

<sup>5</sup>NOT ON 6x6

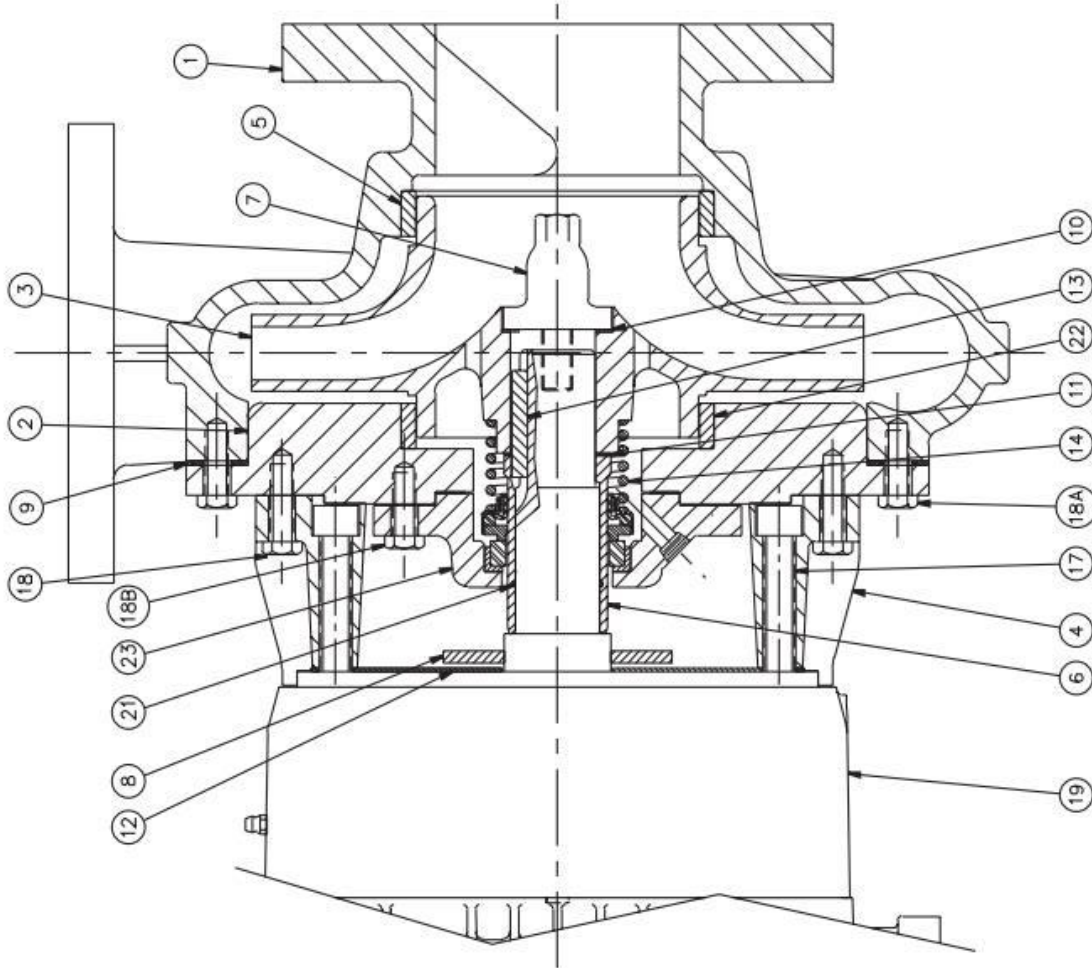

## Applications

---

Your Q-Pumps pump was selected for a specific service. Other Q-Pumps pump styles are available to successfully handle many additional applications including the following partial list. Ask your Q-Pumps representative for complete information.

abrasive slurries	fatty acid	sodium chloride
activated carbon filter slurries	fermentation gas	sodium fluoride
acetone	formaldehyde	sodium hydroxide
alum solution	glycerin	solvent
amide solution	Hydrofluosilicic acid	spin bath solution (rayon)
anodizing solutions	hydrofluoric acid	starch
beer	lard oil and fatty acid	sugar liquor
beer filter slurry (diatomaceous earth)	luminescent solutions	stillage with solids
brine solutions	marine sanitary service	sulfuric acid
cane juice	marine water desalting equipment	tall oil
carbon suspension	molasses	tea
carbon tetrachloride	nitric acid	vinegar
caustic	oleic acid	vegetable oil
chromic acid	phosphoric acid	vinyl liquor
cleaning solutions	plating solution	water solutions
dye	potassium acetate	(corrosive and/or abra- sive)
deionized water	polyethyl benzene	whey
ethylene glycol	salt water (oil field)	wort (beer and molasses)
	sludge fuel	yeast cream

Consult Q-Pumps Company for applications not listed.

# Troubleshooting

---

## Troubleshooting

It is to the user's advantage to be familiar with a systematic procedure to determine reasons and causes for unsatisfactory pump operation. The following list of troubles and causes is intended to assist users in determining the cause of any pumping trouble. Faulty installations can then be corrected and a clear description given to the manufacturer if assistance is required. Human judgement should not be relied on to measure operating conditions. Use proper instruments to measure values of pressure, suction lift, speeds, temperature rise of motors, etc. When motor speeds are incorrect, check connections and measure voltage at the motor terminals.

1. No liquid delivered
  - a. Pump and suction line not completely primed
  - b. Speed too low
  - c. Required discharge too high
  - d. Suction lift too high
  - e. Impeller, piping, or fittings completely plugged up
  - f. Wrong direction of rotation
2. Not sufficient capacity
  - a. Air leaks in suction pipe or shaft seal
  - b. Speed too low
  - c. Required discharge head too high
  - d. Suction lift too high or insufficient NPSH available
  - e. Impeller, piping, or fittings partially plugged
  - f. Insufficient positive suction head for hot water or other volatile liquids
  - g. Liquid viscosity too high
  - h. Mechanical problems- wear rings worn, impeller damaged, shaft seal defective
  - i. Wrong direction of rotation
  - j. Suction pipe entrance too close to surface of liquid
  - k. Air pocket in pipe high points
3. Not sufficient pressure
  - a. Speed too low
  - b. Mechanical problems- wear rings worn, impeller damaged, shaft seal defective
  - c. Small impeller diameter
  - d. Air or gas in liquid
  - e. Wrong direction of rotation
  - f. Air pockets in pipe high points
4. Pump operates for a while, then quits
  - a. Leaky suction line
  - b. Air leaking in through shaft seal
  - c. Suction lift too high or insufficient NPSH available
  - d. Air or gas in liquid
  - e. Suction piping and fitting not completely freed of air during priming
  - f. Air pockets in pipe high points
5. Pump takes too much power
  - a. Speed too high
  - b. Pumping too much water because required head is lower than anticipated
  - c. Viscosity and/or specific gravity is higher than specified
  - d. Mechanical problems- binding at wear rings from distortion due to piping strains, shaft bent, impeller rubbing casing, and/or stuffing box too tight
  - e. Wrong direction of rotation

## Terms and Conditions

---

**1. ENTIRE AGREEMENT.** This document contains all of the terms and conditions of the agreement (“the agreement”) between Q-Pumps S.A. de C. V. (“Seller”) and the purchaser (“Purchaser”) of the Products (“Products”) to be sold to Purchaser, to the exclusion of any other statements and agreements, and to the exclusion of any terms and conditions incorporated in Purchaser’s order or other documents of Purchaser. Seller’s acceptance of Purchaser’s order is expressly conditioned on Purchaser’s acceptance of the terms and conditions contained herein, and Purchaser, upon placing an order, is presumed to have accepted all the terms and conditions without modification. No alteration, waiver, modification of or addition to the terms and conditions herein shall be binding on Seller unless set forth in writing and specifically agreed to by an officer of Seller. No course of dealing, usage of trade or course of performance will be relevant to supplement or explain any terms used in the agreement. All offers to purchase, quotations and contracts of sale are subject to final acceptance by Seller at its home office at Querétaro, Querétaro.

**2. PRICES.** Prices for Products manufactured by Seller pursuant to written accepted orders will remain firm for thirty (30) days from the date of any subsequent price change.

**3. TERMS OF PAYMENT.** Standard terms are ½% 10 days, 30 days net, from date of invoice unless otherwise stated. If, in the judgment of Seller, the financial condition of Purchaser at any time does not justify continuance of production or shipment on the terms of payment specified, Seller may require full or partial payment in advance. In cases of delays in payment, Seller reserves the right to charge interest on delinquent balances at the rate of 1 ½% per month.

**4. DELIVERY.** Except as otherwise provided expressly stated in the agreement, Products are sold F.O.B. EXW México. Seller will use reasonable commercial efforts to fill orders within the time stated, but the stated delivery date is approximate only, and Seller reserves the right to readjust shipment schedules without liability. Acceptance by Purchaser of the Products waives any claim for loss or damage resulting from a delay, regardless of the cause of the delay. Except as otherwise provided herein, Seller will not be responsible for freight, transportation, insurance, shipping, storage, handling, demurrage or similar charges. Claims by Purchaser for shortages in the Products must be made to Seller in writing within ten (10) days after date of receipt of the Products. No such shortage shall entitle Purchaser to withhold payment for Products which were received by Purchaser. Each such claim shall set forth in detail the basis and amount of such claim.

**5. TAXES AND FEES.** Seller shall pay all present and future sales, excise, privilege, use or other taxes, customs duties, and all other fees or other costs, imposed by any federal, state, foreign, or local authorities arising from the sale, purchase, transportation, delivery, storage, use or consumption of the Products or will, if applicable, provide Seller with an appropriate exemption certificate. Seller shall be under no obligation to contest the validity of any such taxes or to prosecute any claims for refunds or returns.

**6. INSTALLATION.** The Products shall be installed by and at the expense of Purchaser.

**7. LOSS, DAMAGE OR DELAY.** Seller will not be liable for loss, damage or delay resulting from causes beyond its reasonable control, including, without limitation, strikes or labor difficulties, lockouts, acts or omissions of any governmental authority or Seller, insurrection or riot, war, fires, floods, Acts of God, breakdown of essential machinery, accidents, embargoes, cargo or material shortages, delays in transportation, lack of production capacity or inability to obtain labor, materials or parts from usual sources. In the event of any such delay, performance will be postponed by such length of time as may be reasonably necessary to compensate for the delay. In the event performance by Seller under the agreement cannot be accomplished by Seller due to any of the foregoing causes within a reasonable period of time, Seller may, at its option, terminate the agreement without liability.

**8. RETURNS.** No Products or parts may be returned by Purchaser without the prior written consent of Seller.

**9. WARRANTY.** Seller warrants that the Products manufactured by Seller will be free from defects, material and workmanship under normal use and service for a period of one (1) year from date of shipment. In addition, the specified rating of each pump is warranted; however, the characteristic shape of the performance curves may vary from the published standards, and the capacity, head and efficiency guarantees are based on actual shop tests using clear cold water, and therefore the rating is specified in equivalent units of clear cold water. The sole obligation of Seller and the exclusive remedy of Purchaser for breach of this warranty shall be the repair (at Seller’s facility) or replacement by Seller (F.O.B. EXW México), at Seller’s option, of any parts found to be defective, without charge and shall be conditioned upon Seller receiving written notice of any alleged breach of this warranty within a reasonable time after discovery of the defects, but in no event later than the end of the warranty period. The parts alleged to be defective shall be returned to Seller upon its request, freight prepaid. This warranty does not cover ordinary wear and tear, abuse, misuse, overloading, alteration or Products or parts which have not been installed, operated or maintained in accordance with Seller’s written instructions. Seller shall not be liable for any expenses for repairs, additions or modifications to the Products outside of Seller’s factory without its prior written consent, and any such repairs without such consent shall void this warranty. THIS WARRANTY IS EXCLUSIVE AND IS IN LIEU OF ALL OTHER EXPRESS AND IMPLIED WARRANTIES WHATSOEVER, INCLUDING BUT NOT LIMITED TO IMPLIED WARRANTIES OF MERCHANTABILITY AND FITNESS FOR A PARTICULAR PURPOSE. Seller may from time to time provide its facilities, personnel and experience to assist customers in the selection of materials, design, installation and operation of Products for maximum resistance to corrosion and abrasion with due consideration to the economy of the installation. This service is provided in an advisory capacity only and the final selection and operation of the Products and ancillary equipment shall be the sole responsibility of Purchaser or any user thereof. Accessories and parts manufactured by third parties are warranted only to the extent of such third party’s warranty. IN NO EVENT SHALL SELLER BE LIABLE UNDER ANY CIRCUMSTANCES FOR ANY INCIDENTAL, CONSEQUENTIAL OR SPECIAL DAMAGES (INCLUDING, WITHOUT LIMITATION, ANY LOST PROFITS OR LABOR COSTS) ARISING FROM THE BREACH OF THIS WARRANTY OR OTHERWISE ARISING FROM OR RELATING TO THE PRODUCTS OR THEIR SALE, USE OR INSTALLATION.

## Terms and Conditions

---

**10. CHANGES.** Changes in any work to be performed hereunder may be made only upon Purchaser's written instructions and acceptance by Seller in its discretion. Any change in drawings, materials or design of the Products, or to tools, fixtures or other items used to produce the Products, which affects Seller's cost to produce the Products will entitle Seller to adjust the price to take into account any additional costs. If work has been started, Seller shall be properly reimbursed for work already performed; if Products already produced are not accepted by Purchaser, Seller has the right to adjust the price to take into account any additional costs caused by an increase or decrease in quantities or in the time required for performance under the agreement.

**11. TERMINATION.** After Seller has commenced work, ordered any materials or made any other commitments pursuant to the agreement, it may be terminated only with the prior written agreement of Seller providing for equitable cancellation charges. Such charges shall reimburse Seller for any completed items at the contract price, and for any work-in-process items at the contract price less the cost to complete. Termination on any other basis must be specifically agreed on in writing in advance between Purchaser and Seller.

**12. DEFERRED DELIVERIES.** Orders or deliveries will be deferred only upon the prior written agreement of Seller in its discretion, and then only upon the following conditions:

(a) The deferral period may not exceed sixty (60) days. At the end of the deferral period, if no release is provided by Purchaser, Seller reserves the right to render an invoice for and ship the completed portion of the order to the destination specified in Purchaser's order, or to store such material at Purchaser's expense at Seller's standard storage charges then in effect.

(b) For the portion of the order that is not completed, if no release is provided by Purchaser at the expiration of the deferral period, Seller reserves the right to render an invoice for any completed items at the contract price, and for any work-in-process items at the contract price less the cost to complete.

(c) Purchaser shall bear the risk of loss or damage to materials held at Purchaser's request.

**13. LIMITATION OF LIABILITY.** IN NO EVENT SHALL SELLER BE LIABLE UNDER ANY CIRCUMSTANCES: (a) FOR ANY INCIDENTAL, CONSEQUENTIAL OR SPECIAL DAMAGES (INCLUDING, WITHOUT LIMITATION, ANY LOST PROFITS OR LABOR COSTS) ARISING FROM OR RELATING TO THE PRODUCTS OR THEIR SALE, USE OR INSTALLATION; (b) FOR DAMAGES TO PROPERTY (OTHER THAN THE PRODUCTS PURCHASED FROM SELLER); (c) FROM ANY BREACH OF ITS WARRANTY OR ANY OTHER OBLIGATIONS TO BUYER; OR (d) FOR ANY OTHER CAUSE WHATSOEVER, WHETHER BASED ON WARRANTY (EXPRESSED OR IMPLIED) OR OTHERWISE BASED ON CONTRACT, OR ON TORT OR OTHER THEORY OF LIABILITY, AND REGARDLESS OF ANY ADVICE OR REPRESENTATIONS (WHETHER OR NOT IN WRITING) THAT MAY HAVE BEEN RENDERED BY SELLER CONCERNING THE DESIGN, MANUFACTURE, SALE, USE OR INSTALLATION OF THE PRODUCTS.

**14. INFRINGEMENT.** Seller at its expense will defend and hold Purchaser harmless from and against all damages, costs and expenses arising from any valid claim of infringement by a third party with respect to any patent or other intellectual property rights (collectively, the "Intellectual Property Rights") caused by Products originally manufactured by Seller, provided Purchaser (a) has not modified such Products, (b) gives Seller immediate notice in writing of any claim or commencement or threat of suit, and (c) permits Seller to defend or settle the same, and gives all immediate information, assistance and authority to enable Seller to do so. In the event any such originally manufactured Products are held to infringe an Intellectual Property Right and if Purchaser's use thereof is enjoined, Seller will, at its expense and option: (1) obtain for Purchaser the right to continue using the Products, (2) supply non-infringing Products, (3) modify the Products so that they become non-infringing, or (4) refund the then market value of such Products. In no event shall Seller's liability exceed the sale price of the infringing Products. THE FOREGOING REPRESENTS SELLER'S ENTIRE AND EXCLUSIVE OBLIGATION WITH RESPECT TO ANY CHARGE OF INFRINGEMENT OF ANY INTELLECTUAL PROPERTY RIGHT AND IS IN LIEU OF ANY STATUTORY WARRANTY RELATING TO INFRINGEMENT. Notwithstanding the foregoing, Seller shall have no liability as to any Products or parts thereof that are manufactured or modified by Purchaser or a third party, or that are manufactured or modified by Seller in accordance with Purchaser's specifications. Purchaser will defend and hold Seller harmless from and against all damages, costs and expenses whatsoever arising from any claim for infringement of any Intellectual Property Rights relating to Products that have been manufactured or modified by Seller according to specifications provided by Purchaser.

**15. CERTAIN LAWS.** Seller will comply with the applicable requirements of the Fair Labor Standards Act of 1938, as amended, Executive Order 11246, and THE rules, regulations and orders of the Secretary of Labor relating thereto.

**16. PERIOD FOR ACCEPTING QUOTATIONS.** Unless accepted without modification within thirty (30) days of issuance, or prior to withdrawal by Seller if earlier, all quotations automatically expire at the end of such thirty (30) day period.

## Terms and Conditions

---

**17. PROVISIONS FOR INTERNATIONAL TRANSACTIONS.** The following provisions shall apply if the Products are to be shipped to Purchaser at a location outside México, and apply regardless of other provisions set forth in these Terms and Conditions:

(a) The 1980 United Nations Convention on Contracts for the International Sale of Products shall not apply.

(b) Except as otherwise provided expressly stated in the agreement, terms of delivery are Ex-Works (within the meaning of INCOTERMS 2000) and all customs fees, import duties, cargo insurance, taxes and other charges imposed on or relating to the purchase or sale of the Products shall be paid by Purchaser in addition to the stated price.

(c) Except as otherwise provided expressly stated elsewhere in the agreement, payment shall be made by issuance to Seller of an irrevocable letter of credit which (i) is issued and confirmed by a U.S. bank acceptable to Seller, (ii) is governed by the Uniform Customs and Practice for Documentary Credits (UCP 600) and otherwise acceptable in form and substance to Seller, and (iii) provides for payment to Seller of the purchase price in U.S. dollars upon presentation by Seller of Seller's certification and/or such other documents as shall be required by the letter of credit. All banking and other charges for such letter of credit shall be for the account of Purchaser.

(d) Prices include Seller's standard commercial export packaging which may vary depending on whether shipment is made by air, land or sea. Except as otherwise provided expressly stated in the agreement, Purchaser will bear any additional expenses required to satisfy Purchaser's packaging requirements. Packages will be marked in accordance with Purchaser's instructions, if any. Seller shall furnish packing lists and such other information as may be necessary to enable Purchaser's agent to prepare documents required for export shipment.

(e) All shipments hereunder are subject to compliance with the U.S. Export Administration Act, as amended, regulations thereunder and all other U.S. laws and regulations concerning exports. Purchaser shall comply with all such laws and regulations concerning the use, disposition, re-export and sale of the Products provided hereunder.

**18. GENERAL.** No modification or waiver of the agreement or any of its provisions is valid unless expressly agreed to by Seller in writing, and no waiver by Seller of any default under the agreement is a waiver of any other or subsequent default. The unenforceability or invalidity of one or more of the provisions of the agreement will not affect the enforceability or validity of any other provision of the agreement. Purchaser may not assign any of its rights, duties or obligations under the agreement without Seller's prior written consent and any attempted assignment without such consent, even if by operation of law, will be void. The agreement is governed by and shall be construed in accordance with the laws of the State of Wisconsin, including the Uniform Commercial Code as enacted by such state, without giving effect to its conflict of laws principles.

## **Return Policy**

---

This policy is intended for returns that are not covered by product warranty, i.e. wrong pump or part was ordered, customer canceled order, etc. Before returning any product, contact us for a Returned Material Authorization Number (RMA#). This will eliminate confusion when the parts are received and facilitate processing the return. No action will be taken on returned parts without an RMA.

<u>Type of Return</u>	<u>Restocking Charge</u>
Standard pump with a replacement order	10%
Standard pump without a replacement order	15%
Standard parts with a replacement order	5%
Standard parts without a replacement order	10%

Additional restocking charges may be assessed for any of the following circumstances.

1. Special order motors and seals are not returnable unless we have a use for them. Credit will be determined on a case-by-case basis.
2. Impellers that are trimmed to a diameter that we don't regularly use are not returnable. Credit will be determined on a case-by-case basis.
3. Used seals and motors are not returnable.

### Credits

Credit will be issued only after parts are returned and inspected. Customer is responsible for packaging parts so they are returned in "as new" condition. Any labor required by Q-Pumps to return the parts to "as new" condition will be deducted from the credit.





Q-Pumps S.A. de C.V.  
Acceso "A" #103, Fracc. Ind. Jurica  
Querétaro, Qro. México, 76130  
Phone: +52 (442) 218 4570 or +52 (442) 103 3100  
Fax: +52 (442) 218 4577  
Email: [sales@qpumps.com](mailto:sales@qpumps.com)